

# Hana® Orthopedic Surgery Table

**REF** 6875, 6875I, 6875J

## Owner's Manual

This manual is available in the following versions:

- English (EN)
- Spanish (ES)
- French (FR)
- German (DE)
- Italian (IT)
- Portuguese (PTBR)
- Japanese (JA)
- Chinese (ZH)
- Multilingual (ML)

**REF** NW0508 Rev R

Mizuho OSI ©2017

**Mizuho OSI**®



 **MIZUHO OSI**  
30031 AHERN AVENUE  
UNION CITY, CA 94587-1234 USA  
Inside USA: 1-800-777-4674  
Outside USA: +1-510-429-1500  
Fax: 1-510-429-8500



**EC REP**

Emergo Europe  
Prinsessegracht 20  
2514 AP The Hague  
The Netherlands

WWW.MIZUHOSI.COM  
WWW.NEWHIPNEWS.COM

# Table of Contents

---

<b>1</b>	<b>Important Notices</b>	<b>1</b>
1.1	Trademarks and Patents	7
1.2	Disposal of Electrical Components	7
<b>2</b>	<b>Introduction</b>	<b>8</b>
2.1	General Description	8
2.2	Intended Use	9
2.3	User Profile	9
2.4	Training Requirements	9
2.5	Conditions of Use	9
2.6	Product Lifetime	10
2.7	Specifications	10
2.8	Shipping and Storage	11
2.9	Glossary of Terms	11
<b>3</b>	<b>Basic Operation</b>	<b>13</b>
3.1	Table Orientation	13
3.2	Motion Control Box	14
3.2.1	Breaker/Power Panel	15
3.2.2	Control Panel	15
3.3	Hana® Hand Pendant/Control Pad Operation	18
3.4	Emergency Stop Button	20
3.5	Casters	21
3.6	Moving the Table	22
<b>4</b>	<b>Inspection</b>	<b>23</b>
4.1	Acceptance	23
4.2	General Inspection	23
4.3	Pre-Procedure/Post-Procedure	23
4.4	Preventative Maintenance	24
<b>5</b>	<b>Function Check</b>	<b>25</b>
<b>6</b>	<b>Standard Component Installation and Adjustment</b>	<b>27</b>
6.1	Hana® Radiolucent Leg Spars	27
6.1.1	Installing and Removing Leg Spars	28
6.1.2	Adjusting the Leg Spars	30
6.2	Patient Safety Strap	35
6.3	Pelvic Pad and Perineal Post	36
6.4	Lateral Perineal Post and Board Assembly	37
6.5	Traction Boots	39

6.6	Traction Hook Extender .....	40
6.7	Well Leg Support Assembly .....	41
6.8	Hana <sup>®</sup> Arm Boards .....	44
6.9	Jack Mount Assembly .....	48
6.9.1	Installing the Jack Mount Assembly .....	49
6.9.2	Removing the Jack Mount Assembly .....	50
6.10	Femur Lift Assembly .....	51
6.10.1	Connecting the Coiled Hook Motor Cable to the Expansion Junction Box .....	52
6.10.2	Connecting the Coiled Hook Motor Cable to the Femur Lift .....	53
6.10.3	Disconnecting the Coiled Hook Motor Cable and Removing the Femur Lift .....	55
6.10.4	Attaching the Femur Lift Foot Pedal .....	56
6.10.5	Manual Operation of the Femur Lift .....	57
6.11	Femoral Hook Support and Femoral Hook .....	58
6.12	Hana <sup>®</sup> Knee Flexion System <sup>®</sup> For Total Knee Arthroplasty .....	60
<b>7</b>	<b>Hana<sup>®</sup> Table Components .....</b>	<b>66</b>
7.1	Standard Components .....	66
7.2	Disposable Components .....	75
7.3	Hana <sup>®</sup> Patient Care Kits .....	76
<b>8</b>	<b>Surgical Procedure Setups .....</b>	<b>77</b>
8.1	IM Femoral Nailing: Unilateral Skeletal Traction .....	78
8.2	IM Femoral Nailing: Unilateral Skeletal Traction (with Traction Foot Plate Assembly) ....	82
8.3	IM Femoral Nailing: Unilateral Skin Traction .....	86
8.4	IM Femoral Nailing: Lateral Decubitus Position with Bilateral Skin Traction .....	89
8.5	IM Tibial Nailing: Supine with Unilateral Skin Traction .....	92
8.6	Retrograde IM Femoral Nailing: Supine with Unilateral Skin Traction .....	95
8.7	Hip Pinning: Supine With Unilateral Skin Traction .....	99
8.8	Hip Pinning: Supine With Bilateral Skin Traction .....	102
8.9	Anterior Approach Total Hip Arthroplasty .....	105
8.10	Hip Arthroscopy .....	108
8.11	Total Knee Arthroplasty (with Well Leg Support Assembly) .....	111
8.12	Total Knee Arthroplasty (with Left and Right Leg Spars) .....	113
<b>9</b>	<b>Optional Accessories .....</b>	<b>116</b>
9.1	Hana <sup>®</sup> Table Optional Fracture Kit Components .....	116
9.2	Hana <sup>®</sup> Table Recommended Optional Accessories .....	118
9.3	Hana <sup>®</sup> Patient Transfer Board Assembly .....	123
9.3.1	Installing the Hana <sup>®</sup> Patient Transfer Board on the Table .....	124
9.3.2	Removing the Hana <sup>®</sup> Patient Transfer Board from the Table .....	125
9.4	Optional Lateral Perineal Post .....	126
9.5	Cross Arm Support .....	128
9.6	Lower Leg Support .....	129
9.7	Tibial Traction Assembly .....	130
9.8	Drape Rod Assemblies .....	132

9.8.1	Head-End Drape Rod Assembly .....	132
9.8.2	Foot-End Drape Rod Assembly .....	134
9.9	Equipment Cart .....	135
<b>10</b>	<b>Cleaning, Sterilization, and Maintenance .....</b>	<b>136</b>
10.1	Cleaning and Disinfecting .....	136
10.1.1	Table Exterior .....	136
10.1.2	Mizuho OSI Tempur-Pedic® Medical Pads .....	136
10.1.3	Femoral Hook Support and Femoral Hook .....	137
10.1.4	Hana® Knee Flexion System® .....	137
10.2	Sterilization .....	137
10.3	Maintenance .....	138
<b>11</b>	<b>Electrical System .....</b>	<b>139</b>
11.1	Description .....	139
11.2	Power Cord .....	140
11.3	On/Off Circuit Breaker Power Switch .....	140
11.4	Component Circuit Breakers .....	141
11.5	Linear Actuators .....	141
11.6	Battery System .....	141
<b>12</b>	<b>Troubleshooting .....</b>	<b>143</b>
<b>13</b>	<b>Technical Drawings and Parts List .....</b>	<b>146</b>
13.1	Replacement / Spare Parts List .....	146
13.2	Interconnect Diagram, 100V, 120V, 220-230V Models .....	148
<b>14</b>	<b>Technical Support .....</b>	<b>149</b>
14.1	Contact for Parts and Service .....	149
14.2	Order Replacement Parts .....	149
14.3	Return Damaged Parts .....	149
14.4	Send a Part for Repair .....	150
14.5	Warranty .....	150
14.6	European Community Authorized Representative .....	150
<b>15</b>	<b>Appendix .....</b>	<b>151</b>
15.1	Electromagnetic Emissions .....	151
15.2	Electromagnetic Immunity .....	152
15.3	Recommended Separation Distances .....	154

# 1 Important Notices



**WARNING:** To ensure safe operation of the equipment, please **READ THESE INSTRUCTIONS COMPLETELY** and keep this manual readily available for future reference.

Carefully observe and comply with all warnings, cautions, and instructions placed on the equipment or described in this manual.

**NOTE:** *This device is intended for use by trained personnel only. To schedule an in-service, please contact your local Mizuho OSI sales representative, or call **1-800-777-4674** inside the USA or **+1-510-429-1500** outside the USA.*

















**NOTE:** *The application techniques outlined in these instructions are the manufacturer's suggested techniques. The final disposition of each patient's care as related to the use of this equipment rests with the attending surgeon.*

The following symbols are used in this manual and on the equipment:







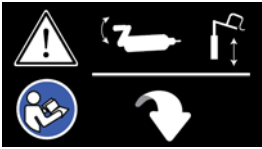

**Table 1: Symbols and their Meanings**

Symbol	Meaning
	This symbol indicates an authorized representative in the European Community.
	This symbol indicates this equipment is an applied part TYPE B in accordance with IEC 60601-1 and is generally suitable for applications involving external or internal contact with the patient, excluding the heart. The patient circuit is connected to protective earth and this equipment should be connected only to hospital grade AC outlets with a protective earth ground.
	This symbol indicates the Manufacturer of the device.
<b>NOTE:</b>	This symbol indicates a comment or instruction of importance.
	This CAUTION symbol indicates a potentially hazardous situation, which if not avoided could result in minor or moderate injury.
	This WARNING symbol indicates a potentially hazardous situation, which if not avoided could result in serious injury or death.
	This symbol indicates proper disposal instructions. See Section 1.2 for more information.
	This symbol indicates a product number.



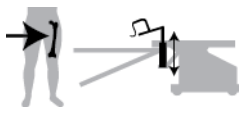

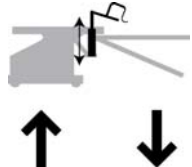

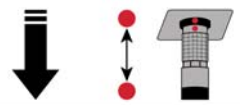
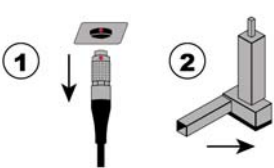

**Table 1: Symbols and their Meanings** (Continued)

Symbol	Meaning
	This symbol indicates a serial number.
	This symbol indicates that you need to consult instructions for use.
	This symbol indicates that you need to read the manual before use.
	This symbol indicates an external ground stud that is required for use when the AC power cable is not connected to a protective earth ground hospital grade AC outlet in your operating room or facility.
	This symbol indicates an external ground stud that is required to be connected to earth ground (via equipotential connector/busbar) when the AC power cable is not connected to a protective earth ground hospital grade AC outlet in your operating room or facility.
	This symbol indicates a potential Pinch Point hazard.
	This symbol indicates the Emergency Stop.
	This symbol indicates the Red Zone. Use a Traction Hook Extender as needed to keep the Traction Brake Cover from entering this zone. See Section 6.6 for more information.
	This symbol indicates rotation in two directions.
	This symbol indicates rotation in one direction.
	This symbol indicates Alternating Current (AC) Power. See Section 3.2.2 for more information.
	This symbol indicates Direct Current (DC) Power.
	This symbol indicates a Circuit Breaker.
	This symbol identifies the Battery Charge LED. When lit, the battery requires immediate charging. See Section 3.2.2 and Section 11.6 for more information.
	This symbol identifies the Battery OK LED. When lit, the battery is charged and ready for use. See Section 3.2.2 for more information.
	This symbol indicates Battery Power.

**Table 1: Symbols and their Meanings** *(Continued)*



Symbol	Meaning
	This symbol indicates Power Connected.
	This symbol indicates Lock.
	This symbol indicates Unlock.
	This symbol indicates rotate counterclockwise to unlock and rotate clockwise to lock.
	This symbol indicates Foot Rotation Lock. Rotate counterclockwise to unlock and rotate clockwise to lock.
	This symbol indicates the Foot Pedal for the Femur Lift Assembly.
	This symbol indicates the location of the Emergency Crank Handle for manual operation of the Femur Lift Assembly. See Section 6.10.5 for more information.
	This symbol indicates the table weight limit.
<p>SM ■</p> <p>LG □</p> <p>XL □</p>	This symbol indicates Small Size.
<p>SM □</p> <p>LG ■</p> <p>XL □</p>	This symbol indicates Large Size (regular).
<p>SM □</p> <p>LG □</p> <p>XL ■</p>	This symbol indicates Extra Large Size.
	This symbol indicates the Left Traction Boot.

**Table 1: Symbols and their Meanings** (Continued)

Symbol	Meaning
	<p>This symbol indicates the Right Traction Boot.</p>
	<p>This symbol indicates the Left Femur Lift.</p>
	<p>This symbol indicates the Right Femur Lift.</p>
	<p>This symbol indicates the Left Femur Lift.</p>
	<p>This symbol indicates the Right Femur Lift.</p>
	<p>This symbol indicates the Foot Pedal moves the Femur Lift up and down. See Section 6.10 for more information.</p>
	<p>This symbol indicates Gross Traction knob. See Section 6.1.2 for more information.</p>
	<p>This symbol indicates the proper method for connecting the Femur Lift cable. Align the red dots on the receptacle and the plug, then insert the plug. See Section 6.10.2 for more information.</p>
	<p>This symbol indicates the proper method for disconnecting the Femur Lift. First disconnect the plug from the receptacle, then remove the Femur Lift. See Section 6.10.3 for more information.</p>
	<p>This symbol indicates that, upon uncrating, the Hana® Table must be charged for three (3) hours before use. If running on DC power, the table must be fully charged and a protective earth ground attached to the table's external ground plug must be used.</p>





**Table 1: Symbols and their Meanings** (Continued)

Symbol	Meaning
	<p>This symbol indicates Hand Pendant connection port. See Section 3.2 for more information.</p>
	<p>This symbol indicates that the table shall not be used as a gurney to transport patients.</p>

 **WARNING:** Proper preoperative and intra-operative procedures must be followed to prevent venous stasis and pooling, pressure sore development, neuropathy, improper electrosurgical tissue grounding, hypertension and hypothermia.

 **WARNING:** This symbol indicates an external ground stud that is required for use when the AC power cable is not connected to a protective earth ground hospital grade AC outlet in your operating room or facility. To protect the patient, hospital staff and the table from possible electrical hazards, an external ground wire connection is required between the external ground stud and protective earth ground when the table is in use under battery power or not connected to a protective earth ground.

 **WARNING:** Use of the Hana® Table with patients weighing more than 450 lbs (204 kg) could result in damage to the table, possible injury to the patient, or harm to the healthcare workers.

 **WARNING:** Before and after each use, inspect the table, components, and accessories for possible damage, excessive wear, or non-functioning parts. Carefully inspect all critical accessible areas, joints, and all moving parts for possible damage or non-function. Damaged or defective parts should not be used or processed. Contact Mizuho OSI Service for repair or replacement (see Section 14).

 **WARNING:** The Hana® Table should not be operated in an oxygen-rich environment, or in the presence of flammable anesthetics, volatile substances, or other explosive gases, liquids, or atmospheres.

 **WARNING:** If high-frequency surgical equipment, cardiac defibrillators, or cardiac defibrillator monitors are to be used with the Hana® Table, refer to the instructions for use provided by the manufacturer of those devices.



**WARNING:** The Hana® Table should not be transported with a patient on it. The table can tip over and cause injury to the patient.



**WARNING:** Use of components not manufactured by Mizuho OSI may result in harm to the patient, the table top, the device, or the healthcare professional.



**WARNING:** Tipping Hazard – Exercise caution when transporting device over uneven surfaces.



**WARNING:** The Hana® Table should not be used for patient transport.



**WARNING:** The Hana® Table is to be used by personnel that receive training from either Mizuho OSI or from someone qualified by the medical facility to provide this training. Failure to comply with this requirement may result in damage to the device, possible injury to the patient, or harm to the healthcare professionals.



**WARNING:** Do not perform any service or maintenance work on the device while it is in use with a patient. Servicing the device while in use may cause injury to the patient.



**CAUTION:** When using the Hana® Radiolucent Leg Spars, always install disposable Leg Spar Ball Joint Protectors. Failure to do so may damage the ball joints on the Leg Spars and will void the warranty on the spars. (See Section 7.3 for ordering information.)



**CAUTION:** When using the Traction Boots, ensure that the proper size is selected for the patient's foot. Using an improperly sized boot and/or excessive over-tightening of the buckle can cause the boot straps to fail. (See Section 6.5 for sizing information.)



**CAUTION:** If the integrity of the AC power source is in doubt, the equipment shall be operated from its internal electrical power source (battery).



**CAUTION:** As outlined in the AORN Recommended Practices for Positioning a Patient in the Perioperative Setting, following the positioning of the patient, an assessment of the patient's alignment, tissue perfusion, and skin integrity should be completed. All contact points of the patient with the table pads should be monitored during the procedure.



**CAUTION:** No modification of the Hana® Table or its components is allowed. Any modification to the equipment may result in damage to the table, possible injury to the patient, or harm to the healthcare workers.



**WARNING:** Use of components not manufactured or recommended by Mizuho OSI may result in harm to the patient, the device, or the healthcare professionals.

## 1.1 Trademarks and Patents

GentleTouch®, Orange Aid®, NervPro®, Knee Flexion System®, Hana®, Hana SSXT®, and ProFx® are registered trademarks of Mizuho OSI.

ProneView® is a registered trademark of Dupaco, Inc.

Tempur-Pedic® and TEMPUR® are registered trademarks of Tempur-Pedic North America, Inc.

Velcro® is a registered trademark of Velcro Industries.

Product protected by:

- US Patent Numbers: US7824353 B2, US9119610 B2
- Australian Patent Numbers: AU2005282927, AU2006280003
- Canadian Patent Number: CA 2578462
- European Patent Number: EP 1799161
- Japanese Patent Numbers: JP 4864893 B, JP 5186369 B
- Korean Patent Numbers: KR 10-1247544, KR 10-1336214
- Chinese Patent Number: CN10129982B

Other Patents Pending

## 1.2 Disposal of Electrical Components



In accordance with the European Union Waste Electrical and Electronic Equipment (WEEE) Directive, all electrical components, batteries, and carbon composite components must be disposed of in accordance with local regulations or returned to Mizuho OSI for proper disposal. Please contact Mizuho OSI Service at **1-800-777-4674** inside the USA or **+1-510-429-1500** outside the USA for further information regarding this requirement.

## 2 Introduction

---

### 2.1 General Description

The Mizuho OSI Hana® Orthopedic Surgery Table is designed to safely hold in proper position a patient undergoing orthopedic surgical procedures including the Anterior Approach Total Hip Arthroplasty, Total Knee Arthroplasty, IM Nailing of the Femur or Tibia, and Hip Pinning.

It is a stand-alone, single-pedestal, AC-powered or internal battery powered table designed to position a patient in a supine or lateral position during surgical procedures.

The table has a 2" (5 cm) Mizuho OSI Tempur-Pedic® pad. The material used in the manufacture of the pads has viscoelastic properties and is a temperature sensitive material, becoming softer where the patient's body is making the most contact with the surface and remaining firm in areas where less body contact is being made. Pressure is distributed evenly over the entire surface area. The pad is radiolucent and is not made with natural rubber latex. The benefits of using Mizuho OSI Tempur-Pedic® pads are improved pressure management, reduced shear forces, and enhanced patient comfort.

The Hana® Table has three primary electrically powered functions: Height (up/down), Lateral Tilt (left/right), and Trendelenburg/Reverse Trendelenburg. Electromechanical actuator motors perform these motions that are controlled by means of a Hand Pendant or onboard Auxiliary Control Panel with functions clearly labeled. The table is also equipped with powered left and right Femur Lifts that are controlled by a Foot Pedal providing the surgeon the ability to raise and lower the Femoral Hook during the Anterior Approach Total Hip Arthroplasty.

Four (4) independent, manual Caster Floor Locks stabilize the table in the operating location.



**Figure 1: Mizuho OSI Hana® Orthopedic Surgery Table, Right-Side View**

## 2.2 Intended Use

The Mizuho OSI Hana® Orthopedic Surgery Table is intended for and suitable for use in the hospital operating room, sub-acute surgical environments, and hospital trauma centers. The Mizuho OSI Hana® Orthopedic Surgery Table is designed for adult and pediatric patients with body weight up to 450 lbs (204 kg), needing hip or knee orthopedic surgical procedure as prescribed by a trained physician.

This device is intended for and designed to provide patient comfort and enhanced patient positioning for surgery.

Due to the design of the tabletop, the operating table is suitable for Hip and Knee Orthopedic surgical disciplines, as described in Section 8.

Movements are initiated manually; they are executed manually or electro-mechanically. Side rails are provided for securing accessories in accordance with the manufacturer's specifications.

The radiolucent tabletop and Leg Spars of the Hana® Table permit intra-operative use of X-ray equipment.

## 2.3 User Profile

The System is suitable for use by health care professionals including, but not limited to, surgeons, radiologists, anesthesiologists, circulating nurses, surgical technicians, biomedical technicians, and radiology technicians.

## 2.4 Training Requirements

Before using the Hana® Table, the user must read the **REF** NW0508 Hana® Orthopedic Surgery Table Owner's Manual.

It is required that personnel using this device and related accessories receive training by either Mizuho OSI or by someone qualified by the medical facility to provide this training.

**NOTE:** *To schedule an in-service, please contact your domestic Mizuho OSI sales representative or call Mizuho OSI Service at 1-800-777-4674 within the USA or +1-510-429-1500 outside the USA.*



**WARNING:** Failure to ensure proper training prior to use of this device may cause harm to the patient, healthcare professional, or the device.

## 2.5 Conditions of Use

The Hana® Orthopedic Surgery Table may be used several times throughout the day and night in medical facilities; e.g. hospitals, and outpatient surgery/imaging centers. The Hana® Orthopedic Surgery Table will be used in an operating room or other treatment room, and may be rolled between rooms.

## 2.6 Product Lifetime

The product's service lifetime is defined as ten (10) years. At the time of delivery, your product fulfills existing regulations and standards. However, despite proper use, routine inspection, prescribed service, maintenance, and repairs, the product is subject to aging and wear. Therefore, Mizuho OSI cannot guarantee the product's safety after ten (10) years and recommends your product be taken out of service. Contact Mizuho OSI Service for product end-of-life disposal instructions (see Section 14). For product warranty information, see Section 14.5.

**NOTE:** *Expected end-of-life for Tempur-Pedic® Medical Pads is three (3) years or sooner, based on use and care.*

**NOTE:** *For optimum performance, ensure that Preventive Maintenance is performed regularly, damaged and worn out parts are replaced, and batteries are replaced as necessary.*

## 2.7 Specifications

The Hana® Orthopedic Surgery Table has the following specifications:

- The table is designed to hold a maximum patient load of 450 pounds (204 kg) in a procedural position at any point within its physical range.
- The table has a height range of 30 to 50 inches (76 cm – 127 cm).
- The width of the tabletop is 21.5 inches (55 cm) and narrows to 10 inches (25 cm) toward the Foot-End and 5 inches (13 cm) at the Perineal Post.
- The length of the tabletop is 48.5 inches (123 cm). The overall length with Leg Spars attached is 124 inches (315 cm).
- The lateral tilt range is  $\pm 12$  degrees and the Trendelenburg/Reverse Trendelenburg range is  $\pm 12$  degrees.
- The Leg Spars rotate on a spherical joint and are capable of positioning the patient's leg in up to 20 degrees of adduction, 45 degrees of abduction, raising the leg to 28 degrees above level and lowering the leg to 35 degrees below level.
- The tabletop has a radiolucent equivalency of less than 1 millimeter of aluminum.
- The input power requirement is 100V, 4A, 50/60Hz; 120V, 4A, 60Hz; or 220-230V, 2.5A, 50/60Hz; as indicated on the table label.
- The table may also be operated under battery power. The expected working life of a fully charged battery is approximately 12 hours at a 10% duty cycle.
- The table is IPX4 rated per IEC 60529.
- The Foot Pedal is rated IP68.
- Operating Environment is 68 °F (20 °C), relative humidity 50%, atmospheric pressure 75-105 kPa.
- Class 1 Equipment; Type B per IEC 60601-1.
- The table is not suitable for use with flammable anesthetic gas mixtures.

## 2.8 Shipping and Storage

The Hana® Orthopedic Surgery Table must be shipped using the appropriate shipping crate. During shipment the table is to be kept in an environment with the following limits:





- Ambient temperature -4 °F (-20 °C) to +122 °F (50 °C)
- Relative humidity from 10% to 100%, including condensation
- Atmospheric pressure from 50 to 110 kPa

When not in use, the Hana® Table and all components and accessories should be stored with care to prevent damage. They should be stored in a clean, dry environment with temperature between 32 °F (0 °C) and 120 °F (49 °C). Keep stored instruments on carts or shelving in a storage area free of dust, insects, chemical vapors, and extreme changes in temperature and humidity. The table cover provided serves as a dust cover and should be utilized.



To ensure the battery is always fully charged and ready for use, the table should be stored with the Power Cord inserted on the Breaker/Power Panel and attached to an appropriate, Hospital-grade AC Outlet (100V, 120V, or 220-230V) and the Power Switch turned On.

## 2.9 Glossary of Terms

**Table 2: Term Definitions**

Term	Description
Foot-End of Table	The end of the table where the leg spar is controlled.
Head-End of the Table	The end of the table where the Power Cord, On/Off Power Switch, and Auxiliary Control Panel are located; also referred to as the pedestal end.
Hospital Grade AC Outlet	Specially designated outlets (receptacles) that include additional grounding reliability, assembly integrity, strength and durability. In the US, Hospital Grade is indicated by a green colored dot on the face of the outlet.
Left Side of the Table	The side to the patient's left in the supine position. This corresponds to the Hand Pendant or Control Pad button labeled  .
Lower the Table	Lowering the height of the tabletop. This corresponds to the Hand Pendant or Control Pad button labeled  .
Pedestal	Main column structure that supports the tabletop.
Raise the Table	Raising the height of the tabletop. This corresponds to the Hand Pendant or Control Pad button labeled  .
Return to Level, or Level the Table	Returning the tabletop to a state of level regardless of its position. This corresponds to the Hand Pendant or Control Pad button labeled  . Holding this button longer than approximately three seconds will also lower the tabletop to its lowest position after the tabletop is leveled.

**Table 2: Term Definitions** *(Continued)*

Term	Description
Reverse Trendelenburg	Raising the height of the Head-End of the tabletop. This corresponds to the Hand Pendant or Control Pad button labeled  .
Right Side of the Table	The side to the patient's right in the supine position. This corresponds to the Hand Pendant or Control Pad button labeled  .
Trendelenburg	Lowering the height of the Head-End of the tabletop. This corresponds to the Hand Pendant or Control Pad button labeled  .



## 3 Basic Operation

---

### 3.1 Table Orientation

The Hana® Orthopedic Surgery Table is described as having a Head-End and a Foot-End. The Control Panel, On/Off Power Switch, and the Power Cord Receptacle are located at the Head-End of the table.

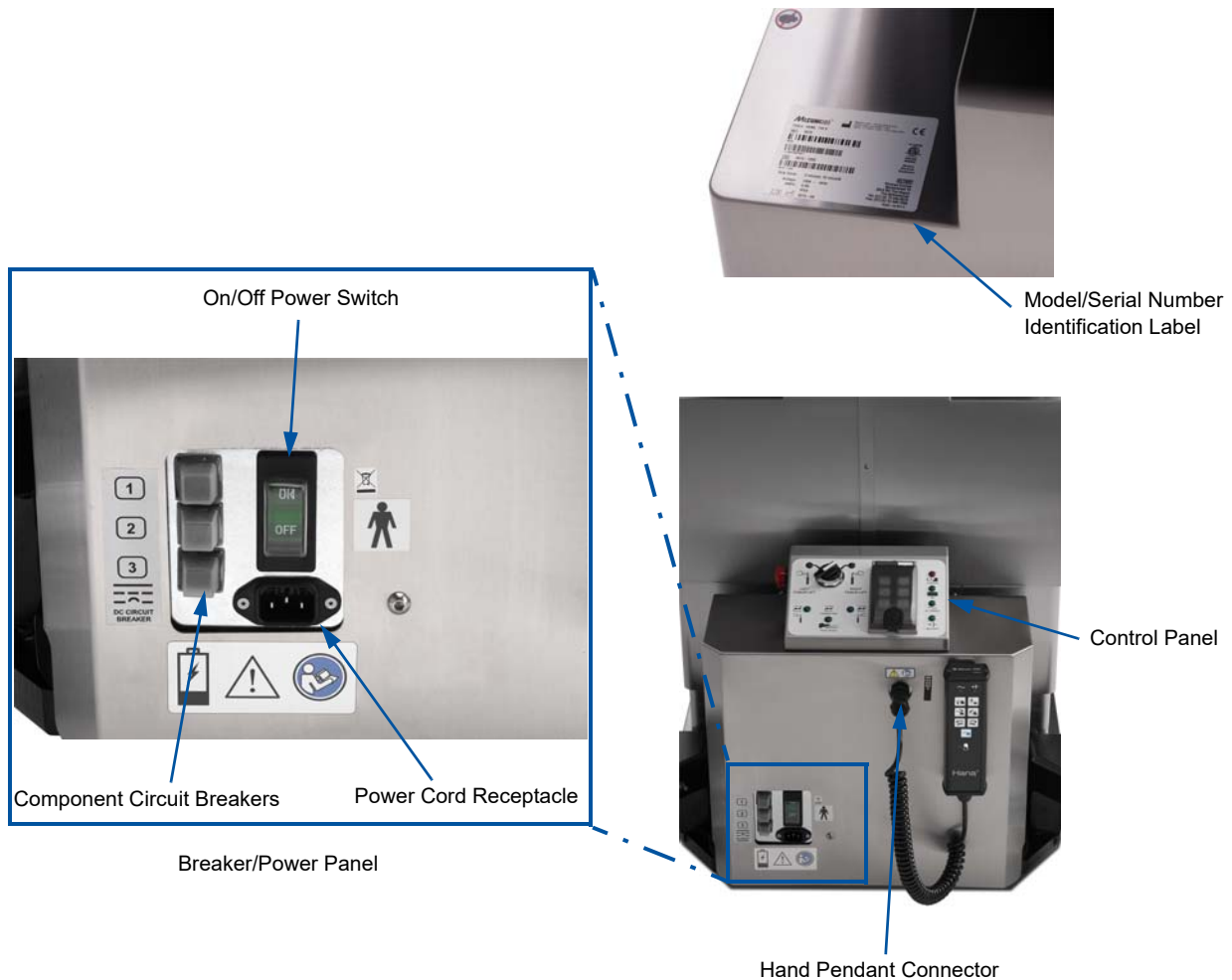

**Figure 2: Right Side View of Hana® Table with Patient in Supine Position**

### 3.2 Motion Control Box

The Motion Control Box is located at the Head-End of the table. It includes the Control Panel, Breaker/Power Panel, Model Number/Serial Number Identification Label, and receptacle for the Hana® Hand Pendant (Figure 3).

The Breaker/Power Panel contains the On/Off Power Switch, Power Cord Receptacle, and Component Circuit Breakers.



**Figure 3: Head-End Motion Control Box**

Input power requirement for the Hana® Table Models 6875, 6875I, and 6875J are indicated on the manufacturer's label:

- 6875J: 100V, 50/60Hz, 4A
- 6875: 120V, 60Hz, 4A
- 6875I: 220-230V, 50/60Hz, 2.5A

### 3.2.1 Breaker/Power Panel

This panel contains the On/Off Power Switch, the Component Circuit Breakers, and the Power Cord Receptacle.

Plug the Power Cord into the Power Cord Receptacle on the Motion Control Box located at the Head-End of the table and into a properly grounded receptacle. Turn on the On/Off Power Switch. The green light in the Power Switch illuminates, indicating that AC power is applied to the table. This switch functions as a combination On/Off Power Switch, Circuit Breaker, and pilot light.

**NOTE:** A startup self-diagnostic routine is initiated each time the table is plugged in and turned on. Wait 20 seconds before operating controls on the table after powering the table on.

**NOTE:** Refer to the Model Number/Serial Number Identification Label on the Head-End of the table for input voltage requirements (Figure 3).

### 3.2.2 Control Panel

The Control Panel is located on the top of the Motion Control Box. It contains the Femur Lift Controls, the Control Pad, and the Power Indicators.







**Figure 4: Control Panel**

### 3.2.2.1 Femur Lift Controls

The Femur Lift Controls consist of a selection switch and three status indicators. Use the Selection Switch to choose whether the Foot Pedal will operate the Left or the Right Femur Lift. The LED indicators below the Selection Switch will illuminate when the Left Femur Lift, Right Femur Lift, and/or Foot Pedal are properly connected.

**Table 3: Femur Lift Controls**

Label	Description
 Select Left Femur Lift	Turn the Selection Switch to the Left Femur Lift to allow the Foot Pedal to operate the Left Femur Lift.
 Select Right Femur Lift	Turn the Selection Switch to the Right Femur Lift to allow the Foot Pedal to operate the Right Femur Lift.
 Left Femur Lift Connected LED	When this LED is illuminated, the Left Femur Lift is properly connected.
 Right Femur Lift Connected LED	When this LED is illuminated, the Right Femur Lift is properly connected.
 Foot Pedal Connected LED	When this LED is illuminated, the Foot Pedal is properly connected.

### 3.2.2.2 Control Pad

The Control Pad and the Hana® Hand Pendant control the table's up/down movement, lateral tilt, and Trendelenburg/Reverse Trendelenburg.

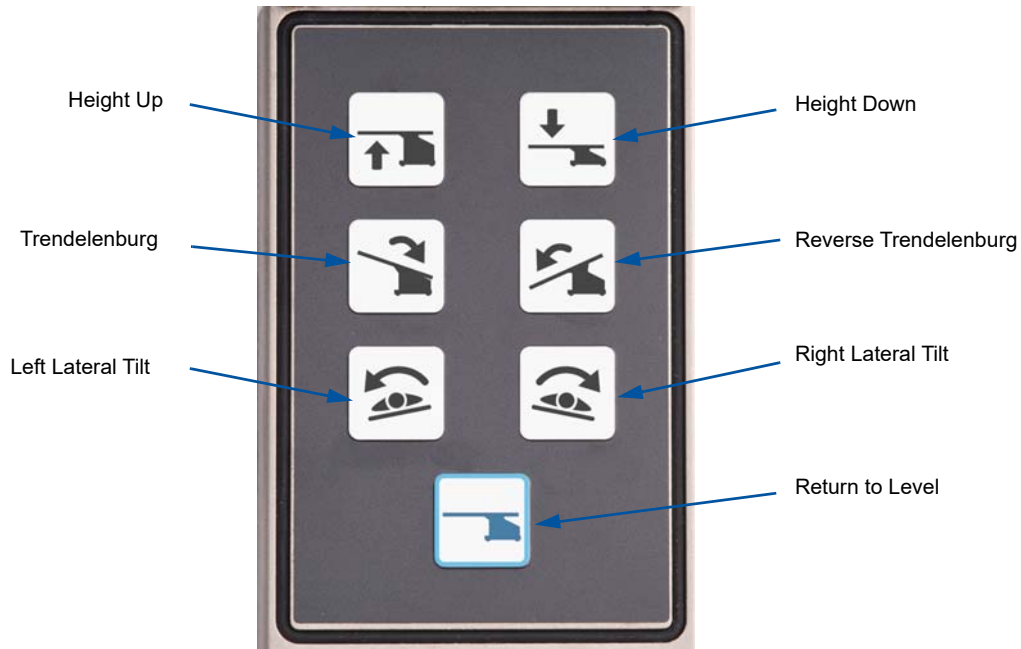





**Figure 5: Control Pad**

For a detailed description of the functions on the Control Pad and the Hand Pendant, see Section 3.3.

### 3.2.2.3 Power Indicators

These LED indicators notify the user of the following conditions when illuminated (Figure 4):

**Table 4: Power LED Indicators**

Symbol	Description
 Battery Charge LED	When this LED is illuminated, battery power is low or no battery is installed. See Section 11.6 for information on charging the battery.
 Battery OK LED	When this LED is illuminated, the battery has sufficient power to operate the table.
 AC Power LED	When this LED is illuminated, the table is running on AC power (100V, 120V, or 220-230V) from the wall receptacle.
 Battery Power LED	When this LED is illuminated, the table is running on internal battery power.

### 3.3 Hana® Hand Pendant/Control Pad Operation

The Hana® Table is controlled using either the Hana® Hand Pendant or the Control Pad on the Control Panel. The Hana® Hand Pendant is plugged into the receptacle on the Motion Control Box (Figure 3). When installing the Hand Pendant, turn the Power Switch off, then plug in the Hand Pendant connector and rotate the locking collar clockwise until the collar is hand tight. To operate any of the desired functions, turn the Power Switch on and wait for 20 seconds for the table to power up and run its self-diagnostics.

To operate any of the desired functions, press and hold the appropriate button on the Hana® Hand Pendant or Control Pad until the desired position is achieved. See Figure 6 and the tables that follow for more information on the Hand Pendant functions and Indicator Lights.









**CAUTION: Ensure the Leg Spars have sufficient clearance before adjusting table position.**





**Figure 6: Hana® Hand Pendant**

**Table 5: Hana® Hand Pendant/Control Pad Functions**

Function	Description
 Height Up	Press and hold the <b>Height Up</b> button to raise the height of the tabletop until the desired height is achieved.
 Height Down	Press and hold the <b>Height Down</b> button to lower the height of the tabletop until the desired height is achieved.
 Trendelenburg	Press and hold the <b>Trendelenburg</b> button to lower the height of the Head-End of the tabletop below the height of the Foot-End of the tabletop until the desired position is achieved.
 Reverse Trendelenburg	Press and hold the <b>Reverse Trendelenburg</b> button to raise the height of the Head-End of the tabletop above the height of the Foot-End of the tabletop until the desired position is achieved.
 Left Lateral Tilt	Press and hold the <b>Left Lateral Tilt</b> button to tilt the tabletop to the left until the desired position is achieved.
 Right Lateral Tilt	Press and hold the <b>Right Lateral Tilt</b> button to tilt the tabletop to the right until the desired position is achieved.
 Return to Level	Press and hold the <b>Return to Level</b> button to return the tabletop to a level position. The tabletop will move in the following sequence: <ol style="list-style-type: none"> <li>1. The tabletop will level side to side (lateral).</li> <li>2. The tabletop will level front to back (Trendelenburg).</li> <li>3. The tabletop will re-level side to side (lateral).</li> <li>4. After a delay of three seconds, the tabletop will move to its lowest height. To achieve this final position, the <b>Return to Level</b> button must be held continuously until table motion stops.</li> </ol> <p><b>NOTE:</b> <i>The controller considers the table to be level if it is within <math>\pm 2^\circ</math> of <math>0^\circ</math> level. If the <b>Return to Level</b> button is pressed while the tabletop is within this range, it will not move. If the table must be adjusted to a position closer to <math>0^\circ</math>, press the appropriate button on the Hana® Hand Pendant until the desired position is achieved.</i></p>

**Table 6: Hana® Hand Pendant Indicator Lights**

Indicator Light	Description
 AC Power	This LED illuminates when the table is operating on AC power.
 Battery Power	This LED illuminates when the table is operating on battery power.
 Battery Status	When this LED illuminates green, the battery is charged and the table is ready to use. When this LED illuminates red, the battery must be charged. See Section 11.6 for more information.

**NOTE:** For information on indicator lights present on the Control Panel, see Section 3.2.2.3.

### 3.4 Emergency Stop Button

To immediately interrupt power to the Hana® Table, press the Emergency Stop button. To reset the system, turn the Emergency Stop button in the direction of the arrows until it returns to its original position (Figure 7).

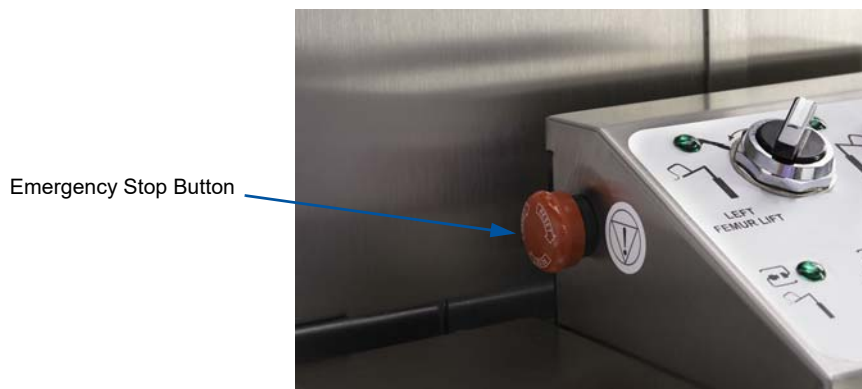

**Figure 7: Emergency Stop Button**



### 3.5 Casters

Prior to transferring a patient onto the table and at all times when the table is in use, ensure that all four (4) independent, manual casters are in the locked position. To engage the lock, step on the foot pad and depress to the floor (Figure 9). To unlock, slide foot under the foot pad and lift to disengage the lock (Figure 8).



**Figure 8: Caster in the Unlocked Position**



**Figure 9: Caster in the Locked Position**

**NOTE:** *The casters and locks installed on your Hana® Table may look different than those depicted above but they will operate in the same manner as described.*

### 3.6 Moving the Table



**CAUTION:** The casters are designed to roll smoothly on level surfaces. If it is necessary to negotiate a high threshold or other uneven surface, a slightly higher speed and/or more people may be required. Take care to control the table's motion.

After all four (4) casters are unlocked the table can be rolled for relocation. It is best that the table be rolled with the Foot-End pointed in the direction of travel, the table lowered to its minimum height, and without the Leg Spars attached to the table. The Hana® Table is heavy and a minimum of two people should move it, one at the Head-End, and one at the Foot-End. Care should be taken to control the table when rolling.



**WARNING:** If the table is allowed to roll too fast, it may be difficult to stop or turn. Impact of the tabletop with a stationary object may cause serious damage to the tabletop. If an impact occurs, the table must be visually inspected for visible damage, and a Function Check must be performed (see Section 6). If damage is discovered or the table does not pass the Function Check, contact Mizuho OSI Service (see Section 14).



**WARNING:** The Hana® Table should not be used for patient transport.

# 4 Inspection

---

## 4.1 Acceptance

Upon receipt of your Hana® Orthopedic Surgery Table, remove it from the shipping crate by following the provided instructions. Remove any protective wrapping or packaging. Visually inspect all surfaces for freight damage. Check each caster for proper rolling operation.

**NOTE:** *Any freight damage must be reported to the freight carrier immediately upon delivery. It is the responsibility of the recipient to make freight damage claims.*

- Read the Model/Serial Number Identification Label found at the Head-End of the table to confirm the serial number and the input power requirements.
- Plug the Power Cord into an appropriate AC receptacle and into the Power Cord Receptacle (located on table-base panel). Power on the table to charge the batteries for at least three (3) hours.
- Place the table in an area with at least four (4) feet of clearance on all sides.
- Perform a Function Check, as described in Section 5.

## 4.2 General Inspection

Before use, inspect the device for possible damage, excessive wear, or non-functioning parts. Visually inspect all accessible areas, electrical cords, and all movable parts for possible damage that may adversely affect the proper operation of the Hana® Orthopedic Surgery Table. Damaged or defective products should not be used or processed. Contact Mizuho OSI Service for repair or replacement of parts (see Section 10).

## 4.3 Pre-Procedure/Post-Procedure

- Inspect and test the table as described in Section 5.
- Inspect pad material for wear or damage.
- Thoroughly clean the table as described in Section 10. Pay special attention to the cleanliness of the controls as excessive soil can affect function.
- Inspect the Power Cord for cuts in the insulation or damage to the connector.
- On a smooth surface with the Caster Locks engaged, push the table. The table should not move.

## 4.4 Preventative Maintenance

A Preventative Maintenance (PM) check on this product is required at least once every year (Section 10.3).

To obtain the PM checklist, call Mizuho OSI Service (see Section 14). PM checks may only be performed by trained service personnel.

## 5 Function Check

---

Perform all steps in this procedure before using the table. For a complete definition of terms used in this procedure, please refer to Section 2.9.

1. Turn the Power Switch off. Plug the Hand Pendant connector into the Hand Pendant Receptacle on the Motion Control Box.
2. If the table is to be used under battery power, turn the Power Switch on and wait for 20 seconds for the table to power up and run its self diagnostics. The **Battery OK** light on the Control Panel should illuminate.



**WARNING:**  This symbol indicates an external ground stud that is required for use when the AC power cable is not connected to a protective earth ground hospital grade AC outlet in your operating room or facility. To protect the patient, hospital staff, and the table from possible electrical hazards, an external ground wire connection is required between the external ground stud and protective earth ground.

3. Perform a battery operation check. Observe either the **Battery OK** indicator light on the Control Panel or the **Battery Status** indicator light on the Hana® Hand Pendant. A green light indicates the table is operating on battery power.
  - If the green **Battery OK** or **Battery Status** light is on, the table is ready to operate normally.
  - If the red **Battery Charge** light on the Control Panel or the red **Battery Status** light on the Hana® Hand Pendant is on, the battery must be charged prior to using the table. To charge the battery, make sure the Power Cord is plugged into a live receptacle and then turn on the Power Switch. This switch will illuminate indicating that appropriate power is applied to the table. The table must remain plugged in and switched on for a minimum of three (3) hours to ensure a battery charge sufficient to operate the table.
  - If the red **Battery Charge** or **Battery Status** light remains on after three (3) hours, continue to charge battery for up to 18 hours.
  - If the green **Battery OK** or **Battery Status** light does not illuminate after 18 hours, refer to Section 11.6.

**NOTE:** *The table may be used with AC power even if the **Battery Status** light is red, indicating batteries need charging.*

4. If the table is to be used under line power, plug the Power Cord into an appropriate hospital grade AC outlet and turn on the Power Switch. Note that the Power Switch illuminates indicating the AC power is on. The **AC Power** lights on both the Control Panel and the Hana® Hand Pendant should illuminate.
5. Perform a Hana® Hand Pendant check:
  - a. Press and hold the **Height Up** button. Verify that the tabletop moves up.
  - b. Press and hold the **Height Down** button. Verify that the tabletop moves down.

- c. Press and hold the **Reverse Trendelenburg** button. Verify that the Foot-End of the tabletop becomes lower than the Head-End.
  - d. Press and hold the **Trendelenburg** button. Verify that the Head-End of the tabletop becomes lower than the Foot-End.
  - e. Press and hold **Left Lateral Tilt** button. Verify that the tabletop tilts to the left.
  - f. Press and hold **Right Lateral Tilt** button. Verify that the tabletop tilts to the right.
  - g. Move the tabletop out of level in both Lateral Tilt and Trendelenburg by five (5) degrees and raise the table at least two (2) inches from its lowest position. Press and hold the **Return to Level** button. Verify that the tabletop first levels from side to side and front to back, and then after a 3-second delay the tabletop moves down to its lowest position.
6. Perform a Control Panel check. Repeat steps 5a through 5g using the Control Pad buttons.
  7. Perform a Femur Lift Control and Foot Pedal check:
    - a. With Femur Lift Assembly connected to electricity, the corresponding light on the Control Panel should illuminate indicating a good connection. See Section 6.10 for proper installation of Femur Lift and Foot Pedal.
    - b. With Left and Right Femur Lift Assemblies and Foot Pedal connected and connectivity indicator lights green, position the Selection Switch located on the Control Panel (Figure 4) to either the Left Femur Lift or Right Femur Lift. Test the Femur Lift Foot Pedal function for operation of the indicated Femur Lift. Repeat for the opposite side.

# 6 Standard Component Installation and Adjustment

---

**NOTE:** *Only Mizuho OSI supplied accessories have been tested and approved for use with the Hana® Orthopedic Surgery Table. Other manufacturers' products have not been tested for proper performance when used with the table, and therefore are not endorsed for use by Mizuho OSI.*

Instructions are provided for setting up and adjusting the following components of the Hana® Orthopedic Surgery Table:

- Hana® Radiolucent Leg Spars
- Patient Safety Strap
- Pelvic Pad and Perineal Post
- Lateral Perineal Post and Board Assembly
- Traction Boots
- Traction Hook Extender
- Well Leg Support Assembly
- Hana® Arm Boards
- Jack Mount Assembly
- Femur Lift(s), Coiled Hook Motor Cable(s), and Femur Lift Foot Pedal
- Femoral Hook Support and Femoral Hook(s)
- Hana® Knee Flexion System®

## 6.1 Hana® Radiolucent Leg Spars

The Hana® Orthopedic Surgery Table is equipped with two Hana® Radiolucent Leg Spars (left and right) that allow for traction, abduction, adduction, and raising or lowering of the leg. When attaching the Leg Spars, ensure that the left Leg Spar is installed on the left side of the table and the right Leg Spar is installed on the right side of the table. The Gross Traction Knob should be positioned laterally.

### 6.1.1 Installing and Removing Leg Spars

Perform the following tasks before installing or removing the Leg Spars:

- Lock the Casters.
- Raise the height of the table to improve access to the spar mount.
- Ensure that the Spar Locking Knob is in the unlocked position by turning the knob counter-clockwise.
- Ensure the Spar Lock Handle is in the locked position.

**NOTE:** *Two people are required for Leg Spar installation and removal. One person supports the distal (foot) end of the Leg Spar by holding the Loop Handle, while another person supports the proximal (head) end of the Leg Spar.*

To install the Hana® Radiolucent Leg Spars:

1. Ensure that the Leg Spar is held firmly at both distal and proximal ends.
2. Insert the proximal end of the left or right Leg Spar into the appropriate Spar Mount (Figure 10).

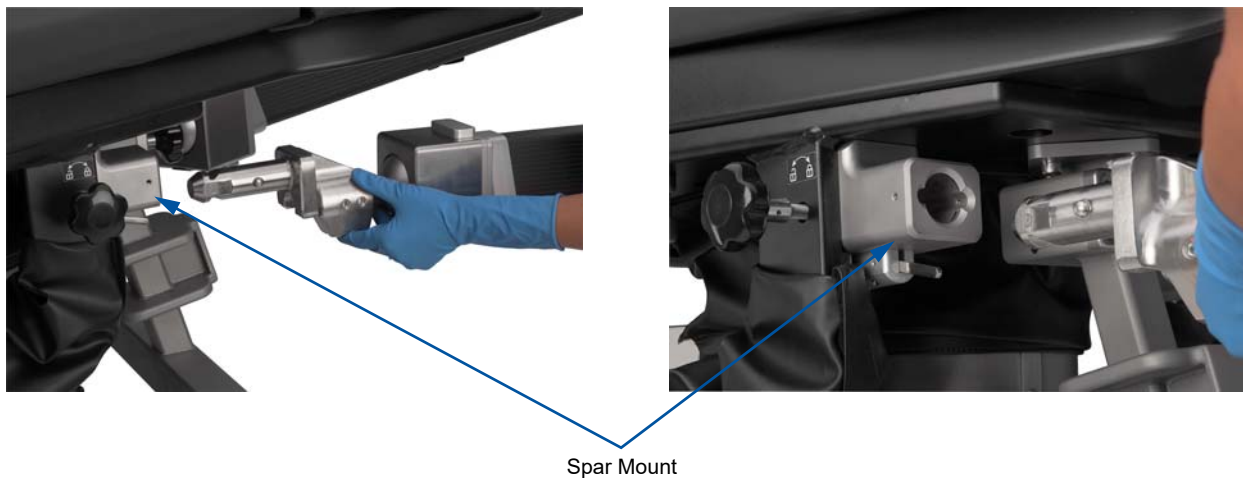

**Figure 10: Mounting the Leg Spar**

3. Slide the proximal end of the Leg Spar forward until it is fully engaged. A click should be heard when the Leg Spar post is inserted past the safety latch.
4. Lock in place by turning the Spar Locking Knob clockwise until tight. Move the Leg Spar up and down slightly while tightening the knob to ensure a tighter lock (Figure 11).





**Figure 11: Locking and Unlocking the Leg Spar**

5. While continuing to support the distal (foot) end of the Leg Spar by holding the Loop Handle, move the Spar Lock Handle to the unlocked position.
6. Reposition the Leg Spar as needed and then return the Spar Lock Handle to the locked position.
7. Before transferring the patient to the table, install the approved Mizuho OSI Leg Spar Ball Joint Protectors (Figure 12).



**CAUTION:** Failure to use the disposable Leg Spar Ball Joint Protectors may damage the ball joints on the Leg Spars and will void the warranty on the spars. (See Section 7.3 for ordering information.)



**Figure 12: Leg Spar Ball Joint Protectors Installed**

To remove the Hana® Radiolucent Leg Spar from the table:

1. Ensure that the Leg Spar is held firmly at both distal and proximal ends.
2. Turn the Spar Locking Knob counterclockwise to unlock the Leg Spar (Figure 11).
3. Lift the safety latch to release it, allowing the Leg Spar to be removed (Figure 11).
4. Slide the Leg Spar out of the Spar Mount.

### 6.1.2 Adjusting the Leg Spars

Each Leg Spar is designed to support the patient's foot in the Traction Boot or with skeletal traction devices and allows for traction, abduction, adduction, and raising or lowering of the leg. It also provides an attachment point for the Knee Flexion System®. When the patient's leg is in the desired position, the Leg Spar can be locked to maintain that position. A dial is provided to gauge the degree of internal and external rotation and should be zeroed out and locked in place utilizing the thumb screw when the foot is in the neutral position. Gross and fine traction are also controlled near the Foot-End of the Leg Spar (Figure 13).

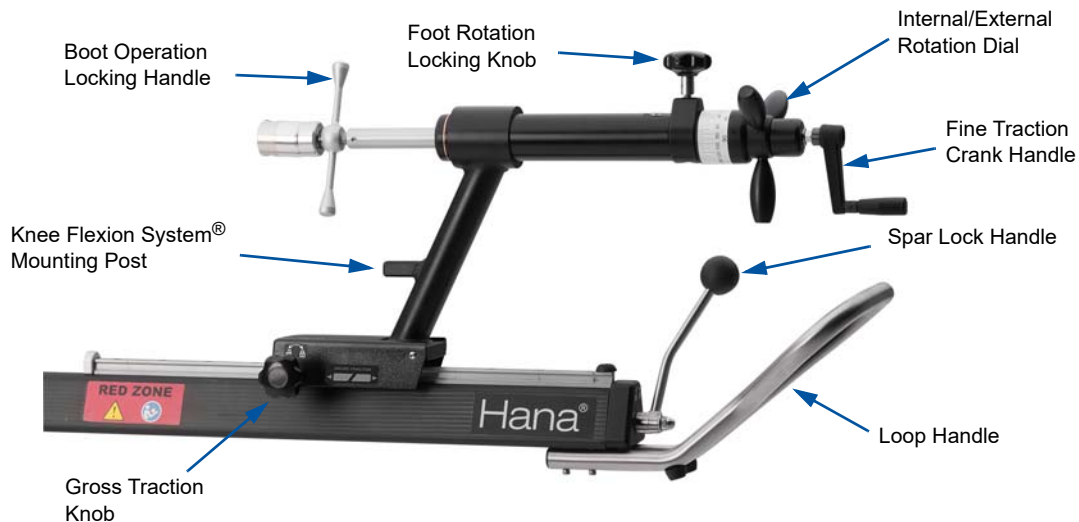

**Figure 13: Hana® Radiolucent Leg Spar Controls**

The Traction Assembly in the Leg Spars can be adjusted as follows:

- To adjust rotation of the Traction Assembly, turn the Foot Rotation Locking Knob counterclockwise to unlock, and then turn the Internal/External Rotation Dial to the desired position. When properly positioned, turn the Foot Rotation Locking Knob clockwise to lock in place (Figure 14).



**Figure 14: Leg Spar Traction Assembly Rotation Adjustment**

- To make gross traction adjustments, turn the Gross Traction Knob at the base of the Traction Assembly counterclockwise to unlock, and then slide the entire assembly to the desired position. When properly positioned, turn the Gross Traction Knob clockwise to lock in place (Figure 15).



**Figure 15: Leg Spar Gross Traction Adjustment**

- To make fine traction adjustments, turn the Fine Traction Crank Handle at the end of the Leg Spar to move the Traction Assembly to the desired position. Rotate the Crank Handle clockwise to add traction. Rotate the Crank Handle counterclockwise to remove traction (Figure 16).



**Figure 16: Leg Spar Fine Traction Adjustment**

During initial patient setup, the gross traction should be adjusted for the patient's height to allow operative traction to be applied and released using the Crank Handle for fine traction adjustments.

**NOTE:** *To allow the surgeon to pull adequate traction on the patient's legs during surgery, the Hana® Table is recommended for use on patients with a maximum inseam that does not exceed 43 inches (Figure 17).*

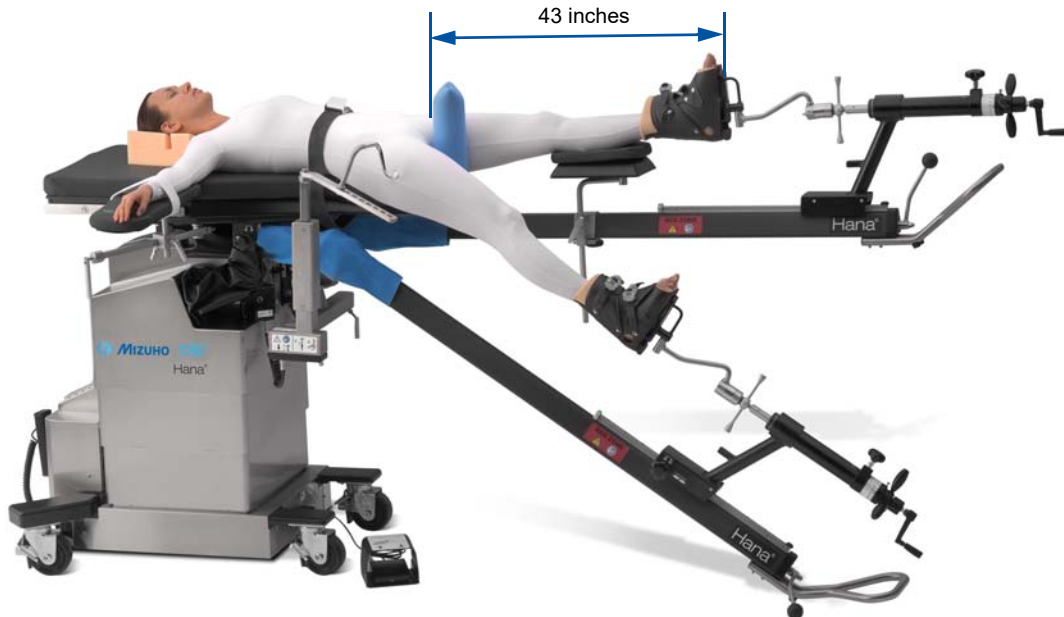

**Figure 17: Maximum Patient Inseam for Hana® Table**

There are approximately 15 inches of adjustment in the fine traction screw. During initial patient setup, position this screw near the center of its travel.

To unlock the spar for abduction, adduction, or height adjustment, hold the Leg Spar with one hand by the Loop Handle and move the Spar Lock Handle (knobbed lever) from the locked to the unlocked position (Figure 18). When you have positioned the leg where needed, lock the Leg Spar by rotating the Spar Lock Handle clockwise to the locked position. If the Leg Spar will not hold position, rotate the Spar Lock Handle further toward the locked position. The Leg Spar should be held securely by the Loop Handle at all times when it is not locked.



**WARNING: Adjusting Leg Spar position can affect traction. Release the Gross Traction Knob while adjusting the Leg Spar position.**

**NOTE:** *If the patient is short in stature and the Traction Brake Cover enters the Red Zone, the installation and use of the Traction Hook Extender is required. See Section 6.6.*

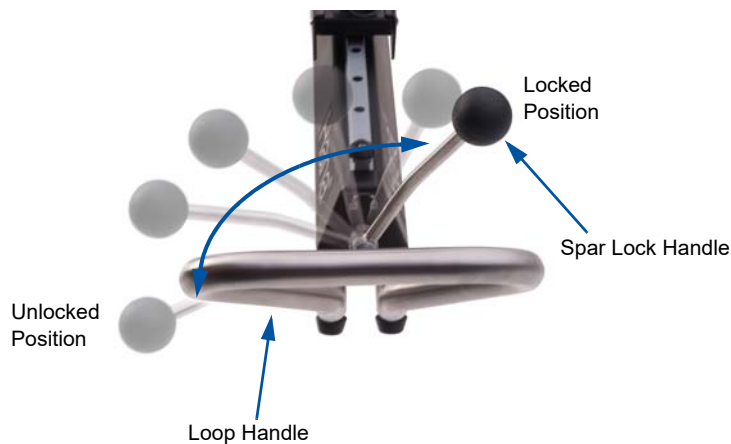

**Figure 18: Spar Lock Handle and Loop Handle on Leg Spar**



**WARNING: Failure to lock the Spar Lock Handle can cause the Leg Spar to drop when not held in place, which could result in damage to the table, possible injury to the patient, or harm to the healthcare professionals.**



**WARNING: Leg Spars can be damaged if allowed to contact the floor during table operation. Clear the area of any obstructions or obstacles during table movement.**



**Figure 19: Hana® Orthopedic Surgery Table with Leg Spars Attached and Set Up for Anterior Approach Total Hip Replacement**

## 6.2 Patient Safety Strap

The Patient Safety Strap is designed to secure the patient to the Hana® Table.



**CAUTION: The Patient Safety Strap is intended to secure the patient to the surgical table. It should not be removed unless the patient is being transferred off the table.**

To install the Patient Safety Strap:

1. Slide the Patient Safety Strap around the Foot-End of the Hana® Table (Figure 20).



**Figure 20: Patient Safety Strap Positioned on Hana® Table**

2. Once the patient is transferred to the table, buckle the Patient Safety Strap around the patient at waist level and pull strap through the buckle until patient is secured firmly to the Hana® Table (Figure 21).



**Figure 21: Patient Secured to Table with Patient Safety Strap**



**CAUTION: The Patient Safety Strap is intended to secure the patient to the surgical table. It should not obstruct or constrict the patient's airway during use.**

## 6.3 Pelvic Pad and Perineal Post

The Pelvic Pad and Perineal Post are used when the patient will be in the supine position on the Hana® Table. The Pelvic Pad supports the patient's pelvis and the Perineal Post provides counter-traction as needed.

To attach the Pelvic Pad and Perineal Post:

1. Prior to transferring the patient to the table, place the Pelvic Pad next to the distal end of the Main Table Pad, and secure with Velcro®. Align the hole in the pad with the Perineal Post attachment hole on the table (Figure 22).



**Figure 22: Pelvic Pad Aligned with Perineal Post Attachment Hole**

2. Immediately after transferring the patient to the table, insert the Perineal Post through the hole in the pad and into the attachment hole on the table.
3. Move the patient to establish firm contact with the Perineal Post and then secure patient with the Patient Safety Strap and the associated Perineal Post.



**WARNING: After transferring the patient to the table, assign at least one attendant to support the patient until safely secured to the table with the Patient Safety Strap and the associated Perineal Post.**

To remove the Pelvic Pad and Perineal Post:

1. After removing anything securing the patient's arms and legs to the table, remove the Patient Safety Strap and the Perineal Post.
2. Upon removal of the Perineal Post, immediately transfer the patient from the table to the stretcher.



**WARNING: When the patient is no longer secured to the table, assign at least one attendant to support the patient until safely transferred to the stretcher.**

3. Once the patient has been safely removed from the table, the Pelvic Pad may be removed.



## 6.4 Lateral Perineal Post and Board Assembly

The Lateral Perineal Post and Board Assembly are used when the patient will be in the lateral decubitus position on the Hana® Table. The Lateral Board supports the patient's pelvis and the Lateral Perineal Post provides counter-traction as needed.

To attach the Lateral Perineal Post and Board Assembly:

1. Align the board holders on the Lateral Board around the left and right edges of the Foot-End of the table top.
2. Slide the Lateral Board toward the Head-End of the table until it abuts the main table pad (Figure 23). Ensure that the notch at the distal end of the pad aligns with the Perineal Post attachment hole.



**Figure 23: Sliding Lateral Board in Place**

3. Place the Lateral Board plug into the Perineal Post attachment hole on the table (Figure 24). This secures the Lateral Board in place at the distal end.



**Figure 24: Lateral Board with Plug Inserted**

4. Immediately after transferring the patient to the table and repositioning from the supine to the lateral decubitus position, slide the Lateral Perineal Post in place on the side notch of the Lateral Board on the patient's anterior side.



**WARNING: After transferring the patient to the table, assign at least one attendant to support the patient until positioned laterally and safely secured to the table with the Patient Safety Strap and the Lateral Perineal Post.**

5. Move the patient to establish firm contact with the Lateral Perineal Post and then secure patient with the Patient Safety Strap and the Lateral Perineal Post.

To remove the Lateral Perineal Post and Lateral Board Assembly:

1. After removing anything securing the patient's arms and legs to the table, remove the Patient Safety Strap and the Lateral Perineal Post.
2. Upon removal of the Lateral Perineal Post, immediately transfer the patient from the table to the stretcher.



**WARNING: When the patient is no longer secured to the table, assign at least one attendant to support the patient until safely transferred to the stretcher.**

3. Once the patient has been safely removed from the table, the Lateral Board Assembly may be removed. Remove the lateral board plug from the Perineal Post attachment hole and slide the Assembly off the table top.

## 6.5 Traction Boots

Skin traction may be facilitated by securing Traction Boots to the Traction Unit of the Leg Spar.

To secure the Traction Boot to the Leg Spar:

1. While the patient is still on the stretcher, slide the Traction Boot onto the patient's foot and secure with buckles.
2. After transferring the patient to the table, insert the post on the Boot Plate Assembly into the Leg Spar Traction Mount (Figure 25) and secure with the thumbscrew.



Figure 25: Traction Boot Secured to Leg Spar

Use the Leg Spar to make traction and rotation adjustments. See Section 6.1.2 for more information.

Traction Boots are provided in two sizes: small and large. Extra-large Traction Boots are also available as an optional accessory. See Section 9 for more information.

Refer to the following size chart to select the appropriate Traction Boot. Adjust the amount of padding as needed for the size of the patient's foot.

Men's Shoe Size Comparison Chart																
	Small Traction Boot				Large Traction Boot							Extra-Large Traction Boot				
<b>UK</b>	4½	5	5½	6	6½	7	7½	8	8½	9	9½	10	10½	11	11½	12
<b>US</b>	5½	6	6½	7	7½	8	8½	9	9½	10	10½	11	11½	12	13	14
<b>EU</b>	37½	38	38½	39	40	40½	41	42	42½	43	44	44½	45	46	46½	47
<b>JP</b>	23.5	24	24.5	25	25.5	26	26.5	27	27.5	28	28.5	29	29.5	30	31	32



**CAUTION:** When using the Traction Boots, ensure that the proper size is selected for the patient's foot. Using an improperly sized boot and/or excessive over-tightening of the buckle can cause the boot straps to fail.

## 6.6 Traction Hook Extender

If the patient is short in stature and the Traction Brake Cover enters the Red Zone, the installation and use of the Traction Hook Extender is required. The Traction Hook Extender secures to the Leg Spar Traction Mount. The Traction Boot attaches to the hook at the end of the Traction Hook Extender, as shown in Figure 26.

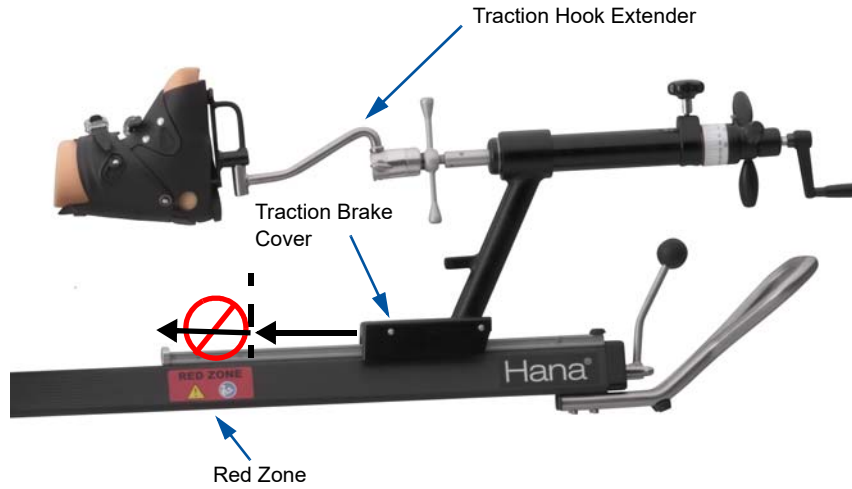

**Figure 26: Using a Traction Hook Extender for Patients Short in Stature**

## 6.7 Well Leg Support Assembly

The Well Leg Support Assembly is an option available for supporting the non-operative leg when the patient is in the supine position (Figure 27).

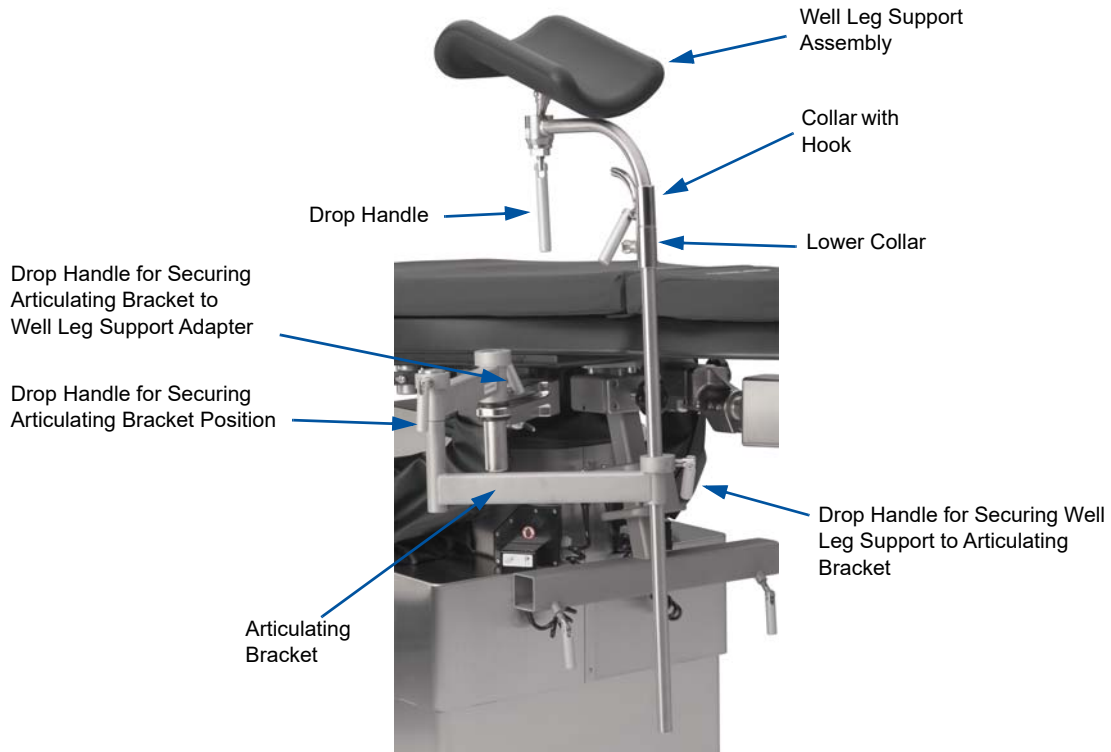

**Figure 27: Well Leg Support Assembly**

To attach and adjust the Well Leg Support Assembly:

1. Insert the proximal end of the Well Leg Support Adapter into the appropriate Spar Mount (Figure 28).



**Figure 28: Installing Well Leg Support Adapter into Spar Mount**

2. Slide the proximal end of the Well Leg Support Adapter forward until it is fully engaged. A click should be heard when the adapter is inserted past the safety latch.
3. Lock in place by turning the Spar Locking Knob clockwise until tight (Figure 29).

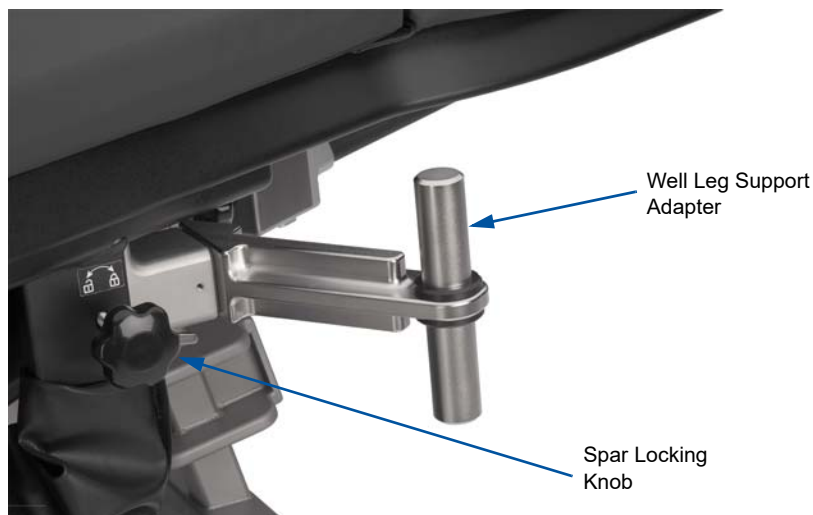

**Figure 29: Well Leg Support Adapter Locked in Place**

4. Slide the Articulating Bracket onto the post at the distal end of the Well Leg Support Adapter (Figure 30) and secure by rotating the drop handle clockwise (Figure 27).



**Figure 30: Securing the Articulating Bracket in Place**

5. Rotate the lower arm of the Articulating Bracket to the desired angle. Secure in place by rotating the drop handle at the joint of the upper and lower arms of the Articulating Bracket clockwise (Figure 27).
6. Attach the Well Leg Support Assembly to the lower arm of the Articulating Bracket and secure in place by rotating the T-handle on the Articulating Bracket clockwise (Figure 27).

The Well Leg Support Assembly provides the following adjustment options (Figure 27):

- **Adjust the Well Leg Support Pad angle:** Rotate the drop handle under the Leg Pad counterclockwise to loosen the ball joint under the Leg Pad, adjust the angle of the Well Leg Support Pad, and then rotate the drop handle clockwise to lock in place.
- **Adjust the hook orientation:** Rotate the drop handle on the collar with the hook counterclockwise to loosen, adjust the height and orientation of the hook and collar, and then rotate the drop handle clockwise to lock in place. The hook provides a second anchor for wraps used to secure the patient's leg.
- **Adjust the lower collar position:** Rotate the drop handle on the lower collar counterclockwise to loosen, adjust the height of the collar, and then rotate the drop handle clockwise to lock in place. This acts as a secondary height positioner for the Well Leg Support Assembly.

## 6.8 Hana® Arm Boards

The Hana® Arm Boards attach to the Swing Bars on the left and right side of the Hana® Table (Figure 31). They can be used to support the patient's arms when in the supine position. If the patient is in the lateral decubitus position, use one Hana® Arm Board in conjunction with the optional Cross Arm Support.



**Figure 31: Close-up of Hana® Arm Board Installed on Table**



To install the Hana® Arm Boards:

1. Rotate the drop handle at the distal end of the Swing Bar counterclockwise to unlock, and move the Swing Bar out from under the table top (Figure 32).



**Figure 32: Moving the Swing Bar**

2. Rotate the smaller of the two drop handles on the Holding Clamp counterclockwise to loosen the Holding Clamp.
3. Insert the post of the Hana® Arm Board into the slot on the Holding Clamp (Figure 33).



**Figure 33: Inserting Hana® Arm Board into Holding Clamp**

4. When the Hana® Arm Board is at the appropriate height, rotate the larger of the two drop handles on the Holding Clamp clockwise to secure the Hana® Arm Board in place.
5. Slide the Holding Clamp along the Swing Bar to adjust the horizontal position of the Hana® Arm Board in relation to the table. Once properly positioned, rotate the smaller of the two drop handles on the Holding Clamp clockwise to secure the clamp's position.
6. Adjust the angle of the Hana® Arm Board in relation to the table by moving the Swing Bar. Once properly positioned, rotate the drop handle at the distal end of the Swing Bar clockwise to lock in place.



**Figure 34: Range of Motion of Swing Bar**

## 6.9 Jack Mount Assembly

The Jack Mount Assembly supports the Femur Lift(s) and/or the optional Hana® Patient Transfer Board. It is designed to be removed and reinstalled as needed, depending on the type of surgical procedures being performed. Removing the Jack Mount allows for C-arm access during Hip Arthroscopy and certain fracture procedures. If C-arm access is not required, or your C-arm can be positioned with the Jack Mount in place, the Jack Mount may remain on the table.

The Jack Mount is located directly underneath the Foot-End of the table top between the Spar Mounts.



**WARNING:** Before use, inspect the device for possible damage, excessive wear, or non-functioning parts. Visually inspect all accessible areas for possible damage that may adversely affect the proper operation of the Hana® Orthopedic Surgery Table. Damaged or defective products should not be used or processed. Contact Mizuho OSI Service (see Section 14) for repair or replacement.

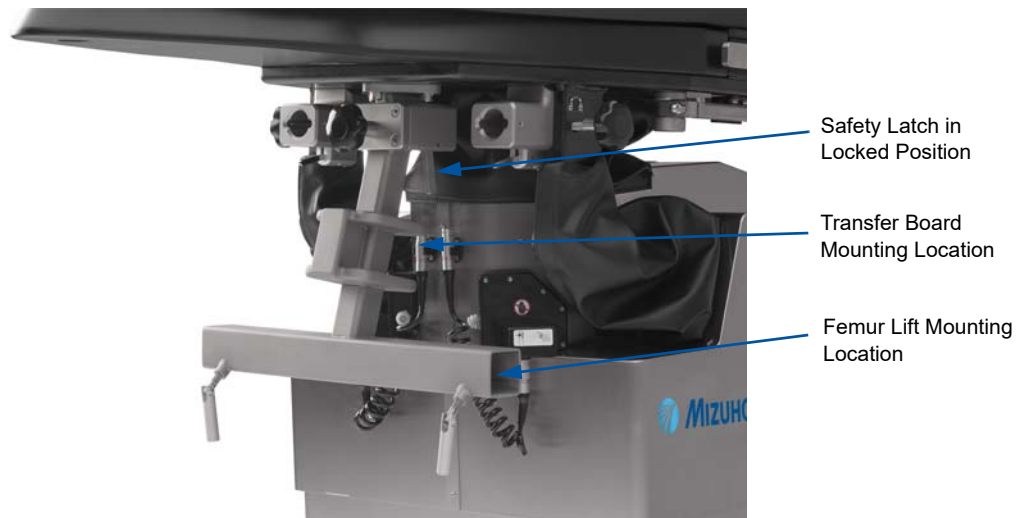
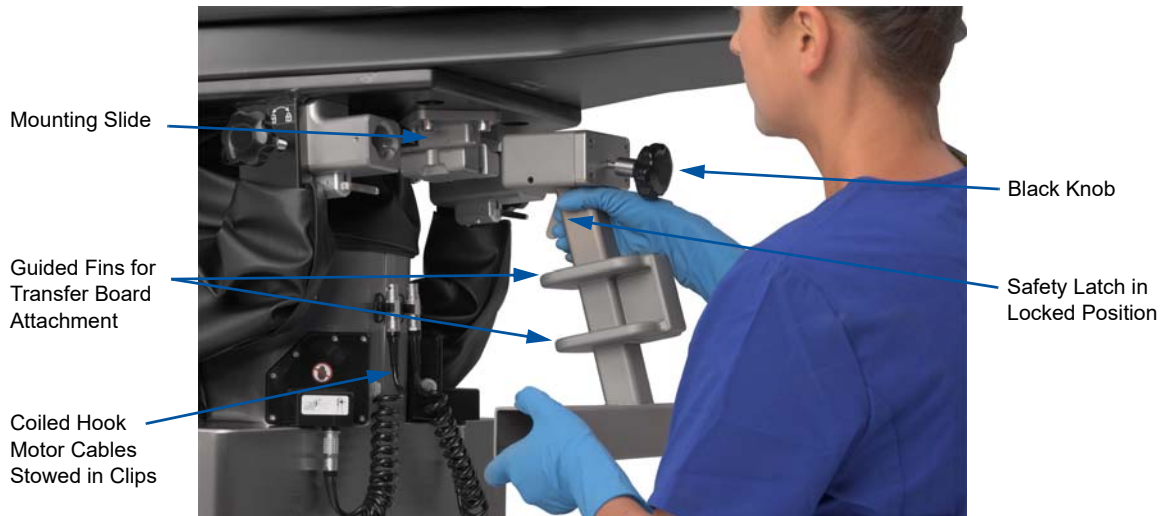

**Figure 35: Jack Mount Assembly Attached, with Leg Spars and Femur Lift Assembly Removed**

### 6.9.1 Installing the Jack Mount Assembly

To install the Jack Mount Assembly:

1. Slide the Jack Mount Assembly into the Mounting Slide on the underside of the tabletop (Figure 36). The safety latch will fall into the locked position. The assembly will move in and out but should be unable to be removed from the slide without first lifting the safety latch.



**Figure 36: Jack Mount Assembly (Safety Latch Locked)**

2. Tighten the black knob to secure the Jack Mount assembly to the table (Figure 36).
3. When the black knob is firmly tight, there should be minimal movement of the Jack Mount Assembly (less than 1/4" at the Jack Mount location).

Before every use, visually inspect the safety latch lever and verify that it is fully engaged and hanging down (Figure 36). Make sure that the black knob is fully tightened and that the Jack Mount is secured to the table.

## 6.9.2 Removing the Jack Mount Assembly

1. If the Femur Lifts are attached to the Jack Mount Assembly, unplug the Coiled Hook Motor cables from the Femur Lifts and secure in the clips behind the Jack Mount Assembly. See Section 6.10 for more information.
2. Remove the Femur Lifts. See Section 6.10 for more information.
3. If the optional Hana® Patient Transfer Board is attached to the Jack Mount Assembly, remove it. See Section 9.3.2 for more information.
4. To remove the Jack Mount Assembly, loosen the black knob to fully disengage the threads (Figure 36).
5. Lift the safety latch to the unlocked position (Figure 37) and pull forward on the Jack Mount Assembly.

The Jack Mount Assembly should slide off freely without excessive force.

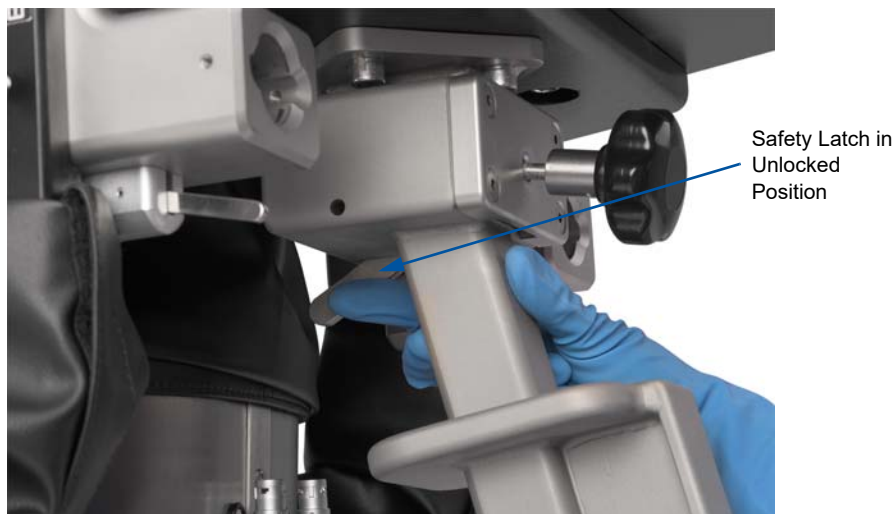

Figure 37: Jack Mount Assembly (Safety Latch Unlocked)



**WARNING:** Do not attempt to install or remove the Jack Mount Assembly from the Hana® Table while the Femur Lifts are still attached to the Jack Mount.

## 6.10 Femur Lift Assembly

The Hana® Orthopedic Surgery Table uses a motorized Femur Lift Assembly to support and adjust the height of the Femoral Hooks for Anterior Approach Total Hip Arthroplasty (AATHA). The Femur Lift Assembly is made up of the following:

- Femur Lifts (Left and Right)
- Coiled Hook Motor Cables
- Femur Lift Extension
- Femur Lift Foot Pedal

The Femur Lift Assembly attaches to two Femur Lift Expansion Junction Boxes (left and right), which are located underneath the table top at the Foot-End. If the Circuit Breaker trips on either of the boxes (Figure 38), the corresponding Femur Lift is powered off.



**WARNING:** If the Circuit Breaker trips on the Left/Right Expansion Junction Box during surgery, the Femur Lift Emergency Crank Handle should be used to move the Femur Lift. Resetting the Circuit Breaker and reusing the Foot Switch to operate Femur Lifts during surgery is not recommended. The table should be properly checked by a trained technician prior to reusing the Foot Switch and Femur Lifts.

**NOTE:** For more information on manual operation of the Femur Lift using the Emergency Crank Handle, see Section 6.10.5.

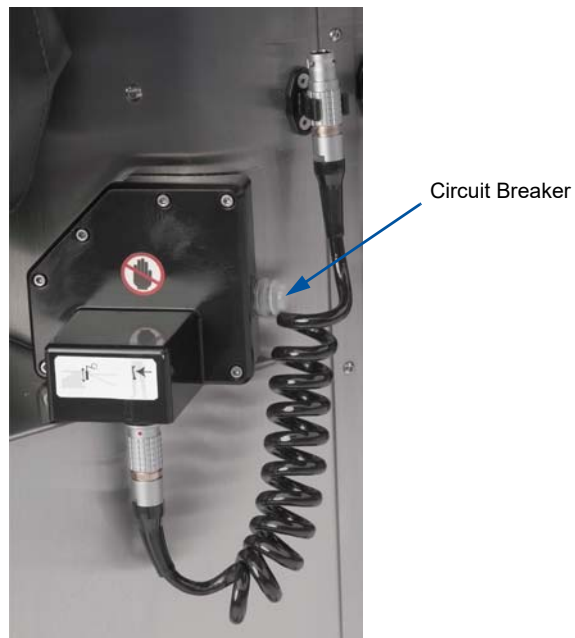

Figure 38: Expansion Junction Box



**Figure 39: Expansion Junction Box (Location)**

### 6.10.1 Connecting the Coiled Hook Motor Cable to the Expansion Junction Box



**Figure 40: Coiled Hook Motor Cables**





**CAUTION:** Before use, inspect the Coiled Hook Motor Cables for possible damage, excessive stretch, or damaged electrical quick-disconnect plugs. Carefully inspect all electrical quick disconnect receptacles and Circuit Breakers for possible damage or non-function. Damaged or defective products should not be used or processed. Contact Mizuho OSI Service for repair or replacement (Section 14).

To connect the Coiled Hook Motor Cables to the Expansion Junction Box (Figure 41):

1. Locate the red dot on the Expansion Junction Box's electrical quick-disconnect receptacle.
2. Orient the Coiled Hook Motor Cable's plug so that the red dot on the plug aligns with the red dot on the Expansion Junction Box receptacle.
3. Push the Coiled Hook Motor Cable's plug into the Expansion Junction Box's receptacle until it clicks.
4. Repeat this procedure for the Expansion Junction Box on the other side.

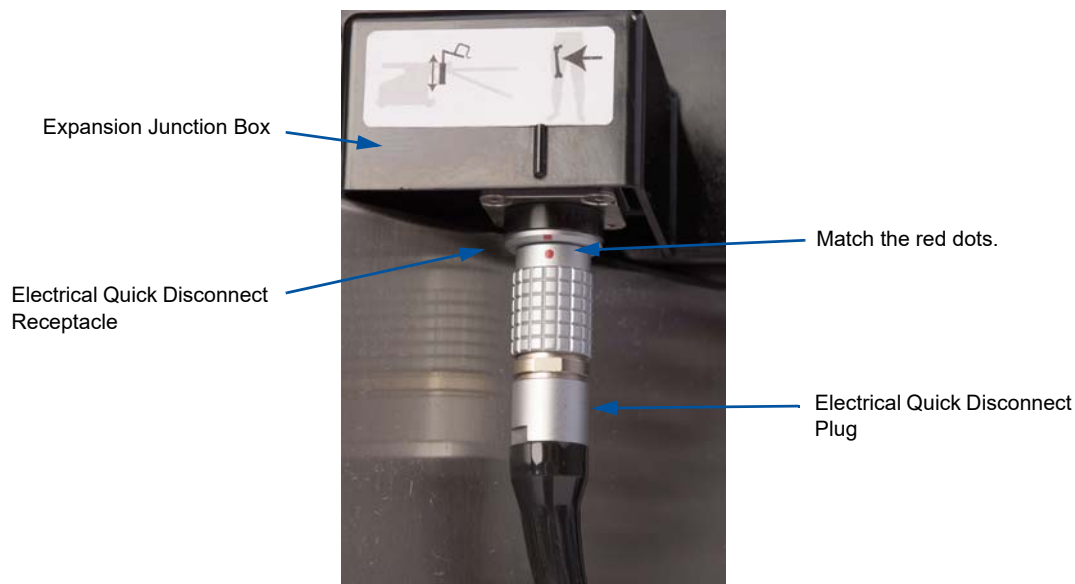

**Figure 41: Connecting the Coiled Hook Motor Cable to the Expansion Junction Box**

### 6.10.2 Connecting the Coiled Hook Motor Cable to the Femur Lift

To connect the Coiled Hook Motor Cable to the Femur Lift:

1. Place the Femur Lift on a flat surface with the red dot of the electrical quick-disconnect receptacle visible.
2. Orient the Coiled Hook Motor Cable's plug so that the red dot on the plug aligns with the red dot on the Femur Lift receptacle (Figure 42).
3. Push the Coiled Hook Motor cable's plug into the Femur Lift receptacle until it clicks.



**Figure 42: Connecting Coiled Hook Motor Cable to Femur Lift**

4. Mount the Femur Lift into the Jack Mount Assembly and tighten the Femur Lift Lock (Figure 43).

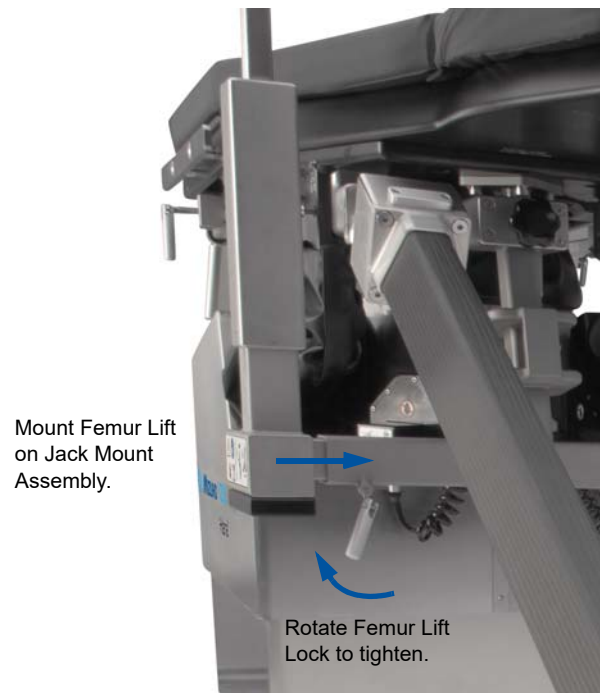
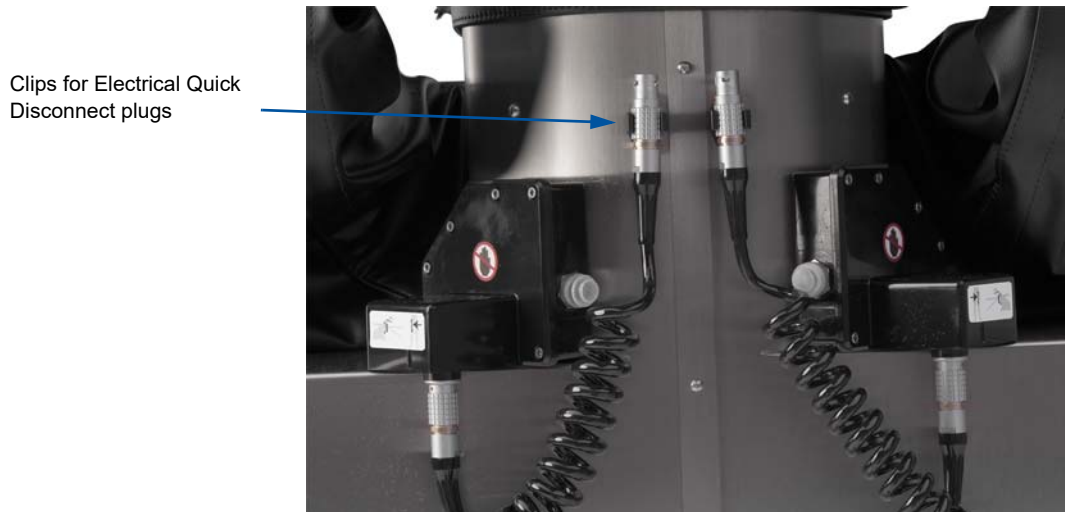

**Figure 43: Femur Lift Mounted on Jack Mount Assembly**

5. Repeat this procedure for the Femur Lift on the other side.

### 6.10.3 Disconnecting the Coiled Hook Motor Cable and Removing the Femur Lift

1. Hold the grooved part of the electrical quick-disconnect plug, and pull down to remove the plug from the Femur Lift receptacle (Figure 42).
2. Stow the electrical quick-disconnect plug of the Coiled Hook Motor Cable into the clip behind the Jack Mount Assembly (Figure 44).



**Figure 44: Clips for Electrical Quick-Disconnect Plugs**

3. Unlock the Femur Lift Lock and remove the Femur Lift from the Jack Mount Assembly.
4. Repeat this procedure for the Femur Lift on the other side.

If a complete removal of the Coiled Hook Motor Cable from the table is desired, repeat step 1 for the other side of the electrical quick-disconnect plug on the Expansion Junction Box. Remove the Coiled Hook Motor Cable from the clip.



**CAUTION: Do not attempt to remove the Femur Lift if the Coiled Hook Motor Cable is connected to it. This can cause damage to the Coiled Hook Motor Cable and the electrical quick-disconnect connectors. Always unplug the Femur Lift first.**

### 6.10.4 Attaching the Femur Lift Foot Pedal

A single Foot Pedal operates both left and right Femur Lifts. Rotate the Femur Lift Control on the Control Panel to the desired setting to switch operation from one Femur Lift to the other (Figure 4).

Plug the Foot Pedal into the port at the Foot-End of the table base. The flange should be flush or below the surface of the receptacle (Figure 45).

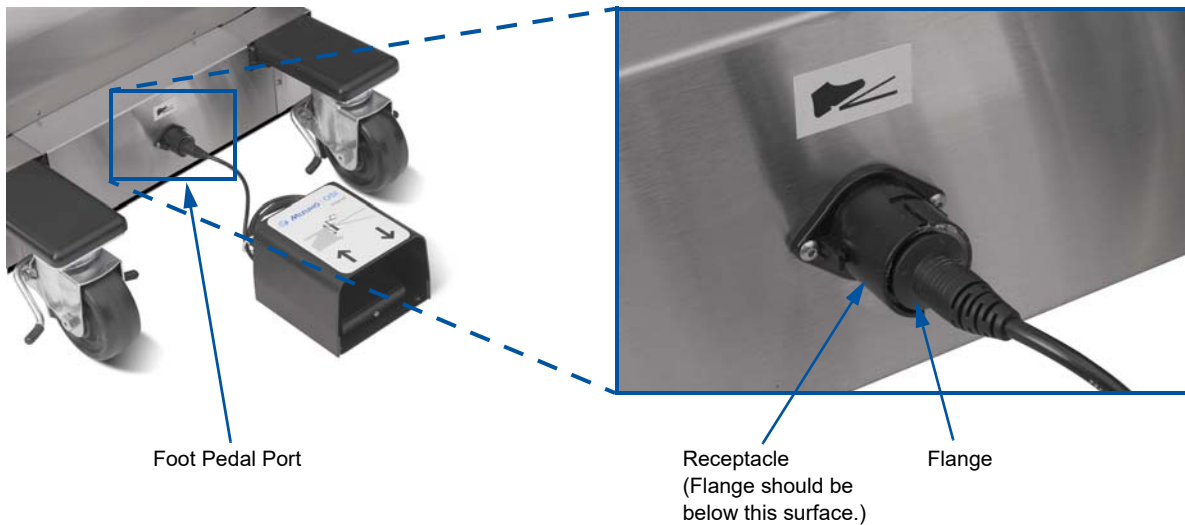

**Figure 45: Plugging in the Foot Pedal**

Prior to surgical setup, perform the following steps to ensure that the Foot Pedal and Femur Lift function correctly.

1. Verify that the Foot Pedal Connected LED is illuminated on the Control Panel (Figure 4).
2. On the Control Panel (Figure 4), rotate the Selection Switch to select either the left or right Femur Lift.
3. Verify that the corresponding LED illuminates, indicating that the Femur Lift is properly connected.
4. Press the Foot Pedal on the left side and observe the Femur Lift rise to its highest position. Then press the Foot Pedal on the right side and observe the Femur Lift lower to its lowest position.
5. Complete this process for both right and left Femur Lifts.

### 6.10.5 Manual Operation of the Femur Lift

If power to the Left/Right Expansion Junction Box is lost during surgery, the Femur Lift may be operated manually using the Femur Lift Emergency Crank Handle. The Femur Lift Emergency Crank Handle is stored underneath the Head-End of the tabletop (Figure 46).



**Figure 46: Femur Lift Emergency Crank Handle Storage Location**

The Femur Lift Emergency Crank Handle is attached to the rear of the Femur Lift Assembly. To operate the Femur Lift manually, insert the Emergency Crank Handle into the opening and rotate the handle to move the Femur Lift up and down (Figure 47).



**Figure 47: Emergency Crank Handle Inserted in the Femur Lift**

## 6.11 Femoral Hook Support and Femoral Hook

The Femoral Hook and Femoral Hook Support are designed for use with only the Mizuho OSI ProFx® Orthopedic Surgery Table, the Mizuho OSI Hana® Orthopedic Surgery Table, or the Mizuho OSI Hana SSXT® Specialty Surgery Table Extension. They provide support for the femur during Anterior Approach Total Hip Arthroplasty. The Femoral Hooks are imprinted with L and R to designate left and right.



**Figure 48: Left and Right Femoral Hooks**

Mizuho OSI's Femoral Hooks and Femoral Hook Support are supplied non-sterile. These surgical instruments require special handling to prevent damage. Misuse can cause excessive stress or strain resulting in damage that can adversely affect their intended use. Before each use, you must do the following:

- Clean and sterilize the instrument(s) according to your hospital's washing, decontamination, and sterilization procedure.
- If the Femoral Hook Support requires reassembly, ensure that the bolt is fully seated (i.e., torqued to 25-30 ft-lbs, or 35-40 Nm) and that the hook bar can rotate freely around the post.
- Inspect the Femoral Hook(s) and Femoral Hook Support for damage, wear, and functionality (check for nicks, burrs, or bent parts).

Proper cleaning, handling, and sterilization will ensure that the Femoral Hook(s) and Femoral Hook Support perform as intended. See Section 10 for more information on proper cleaning and sterilization.

Damaged or non-functioning instruments should not be used or processed. Contact your local Mizuho OSI sales representative or Mizuho OSI Service for repair or replacement.



**WARNING: Use of damaged instruments may increase the risk of tissue trauma, infection, and length of operative procedures.**

To install the Femoral Hook and Femoral Hook Support:

1. Once the patient has been properly positioned and secured to the table, insert the sterilized Femoral Hook Support in the operative-side Femur Lift.



**CAUTION: Do not use excessive force when mounting the Femoral Hook Support on the Femur Lift. Use of excessive force (e.g., hammering with a mallet) may compromise the integrity of the Femoral Hook Support.**

2. Insert the sterilized left or right Femoral Hook in one of the notches on the Femoral Hook Support. Select the notch based on the size and position of the patient that will allow the Femoral Hook to support the femur on the operative side during the procedure (Figure 49).



**Figure 49: Femur Lift in Place for Use with the Femoral Hook Support and Femoral Hook**

3. Use the Femur Lift Foot Pedal to raise or lower the height of the Femur Lift as needed. Press the left side of the Foot Pedal to raise the Femur Lift. Press the right side of the Foot Pedal to lower the Femur Lift. (See Section 6.10 for more information.)

## 6.12 Hana® Knee Flexion System® For Total Knee Arthroplasty

The Hana® Knee Flexion System® is designed for use only in combination with the Mizuho OSI Hana® Orthopedic Surgery Table. It mounts on the operative Leg Spar to support and position the patient's leg as needed during Total Knee Arthroplasty (TKA). It allows for full flexion/extension of the leg and knee as well as internal/external rotation of the foot.

This device is intended to be used above the drapes in the sterile field.

Mizuho OSI's Knee Flexion System® is supplied non-sterile. This surgical instrument requires special handling to prevent damage. Do not apply excessive stress or strain at the joints; misuse will result in damage. Before each use, you must do the following:

- Clean and sterilize the instrument according to your hospital's washing, decontamination, and sterilization procedure.
- Inspect the Knee Flexion System® for damage, wear, and functionality (check for nicks, burrs, or bent parts).

Proper cleaning, handling, and sterilization will ensure that the Knee Flexion System® performs as intended. See Section 10 for more information on proper cleaning and sterilization.

Damaged or non-functioning instruments should not be used or processed. Contact your local Mizuho OSI sales representative or Mizuho OSI Service for repair or replacement.



**WARNING: Use of damaged instruments may increase the risk of tissue trauma, infection, and length of operative procedures.**

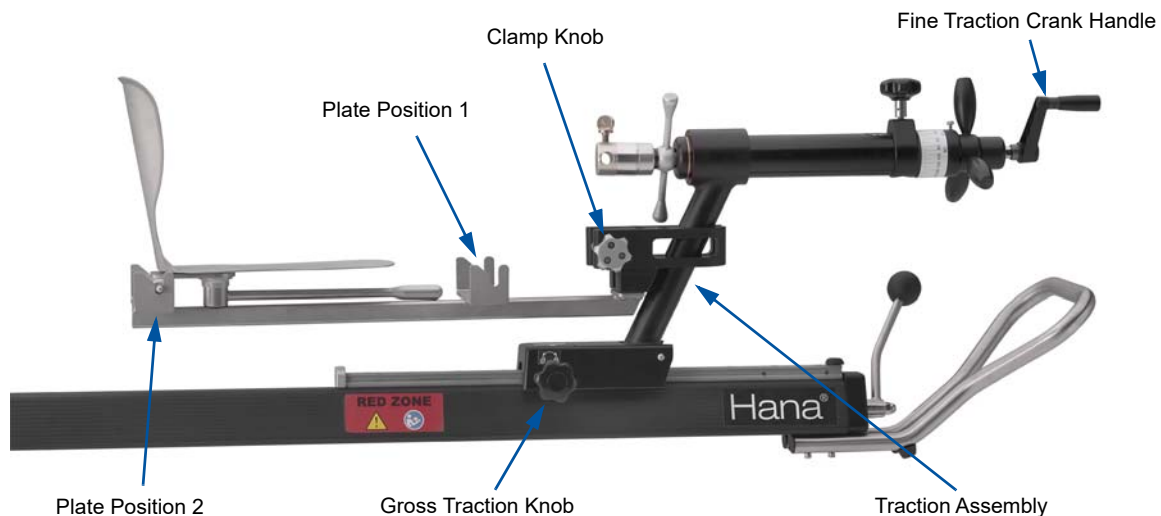

**Figure 50: Hana® Knee Flexion System® Attachment Detail, Leg Spar not Draped**



To attach the Hana® Knee Flexion System® to the Leg Spar (Figure 50):

1. Make sure the Traction Assembly on the Leg Spar is secured in place before attaching the Hana® Knee Flexion System®. Rotate the Gross Traction Knob clockwise to secure, if needed.
2. Adjust fine traction for the operative-side Leg Spar fully towards the Foot-End of the Leg Spar by rotating the Fine Traction Crank Handle clockwise until it stops.
3. Drape the operative side Leg Spar. Clear sterile drapes are recommended to provide improved intraoperative visibility and accessibility.
4. Maintaining sterile technique, rotate the Clamp Knob counterclockwise to loosen the Attachment Brackets on the Knee Flexion System®.
5. Mount the Knee Flexion System® on the Traction Assembly and rotate the Clamp Knob clockwise to tighten the Attachment Brackets (Figure 51).



**Figure 51: Hana® Knee Flexion System® Attached to Traction Assembly**

6. Place the Foot Plate on the Foot Plate Holder (Figure 52). The Foot Plate may be attached at Plate Position 1 or 2, depending on amount of knee flexion desired.

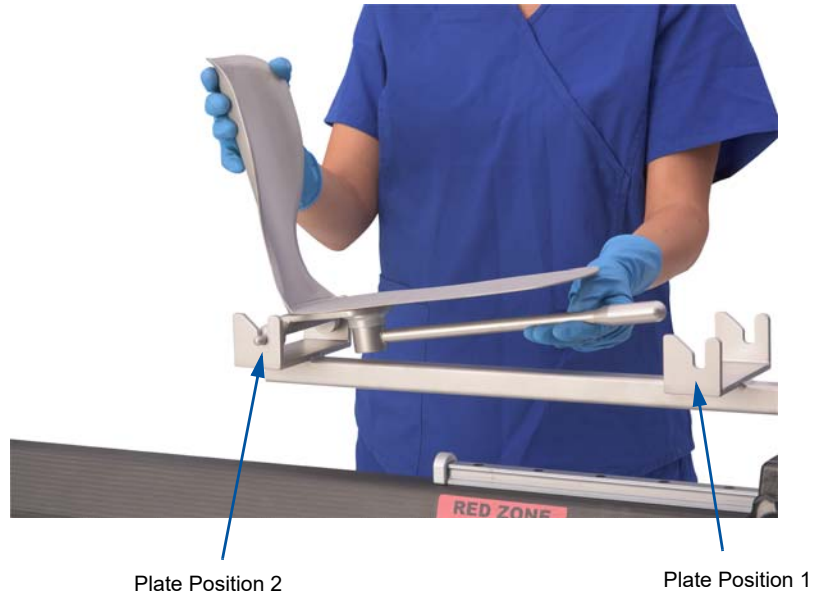

**Figure 52: Foot Plate Placed on the Foot Plate Holder**



**Figure 53: Hana® Orthopedic Surgery Table Set Up for Right TKA, Leg Spar Draped**

To adjust internal/external rotation of the foot:

1. Rotate the Clocking Adjustment Handle counterclockwise to release the Foot Plate (Figure 54).

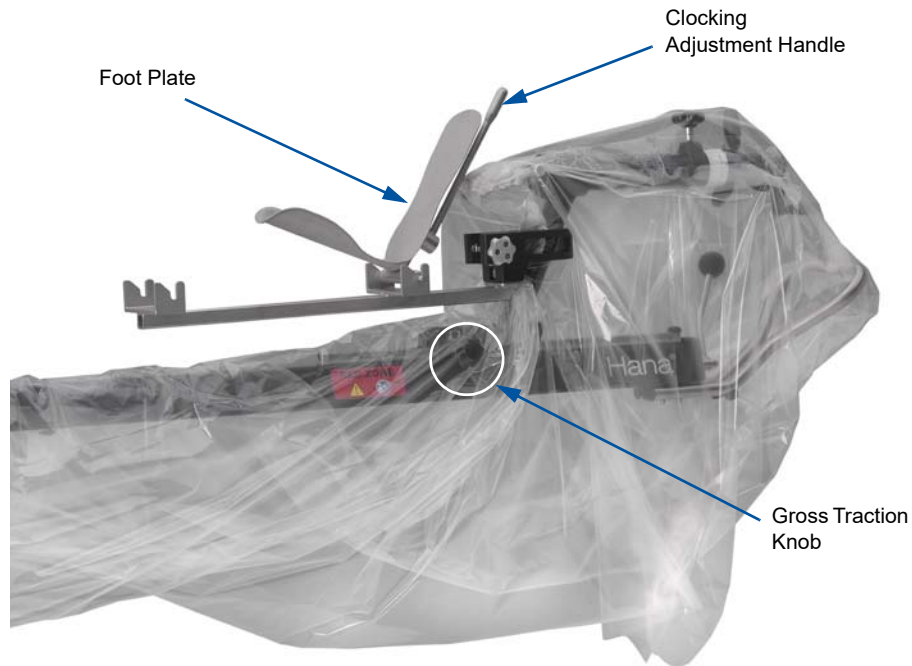

**Figure 54: Hana® Knee Flexion System® Foot Plate and Clocking Adjustment Handle**

2. Adjust the position of the Foot Plate to achieve the desired internal/external rotation.
3. Rotate the Clocking Adjustment Handle clockwise to secure the Foot Plate in position.

The Hana® Knee Flexion System® allows for full flexion/extension of the leg and knee. To obtain flexion of 120° or more, attach the Foot Plate to Plate Position 2, as shown in Figure 55. To obtain flexion of 90° or less, attach the Foot Plate to Plate Position 1 or to Plate Position 2, as shown in Figure 56. To further reduce flexion, attach the Foot Plate to Plate Position 1 and use the Gross Traction Knob to move the traction assembly of the Leg Spar. In this way, the operative leg can be fully extended (Figure 57).



**Figure 55: Table Set Up for Total Knee Arthroplasty with Knee Flexion System® Foot Plate in Position 2, Knee at 120°+ Flexion**



**Figure 56: Table Setup for Total Knee Arthroplasty with Knee Flexion System® Foot Plate in Position 2, Knee at 90° Flexion**



**Figure 57: Table Setup for Total Knee Arthroplasty with Knee Flexion System® Foot Plate in Position 1, Knee at Full Extension by Adjusting Gross Traction**



# 7 Hana® Table Components

## 7.1 Standard Components

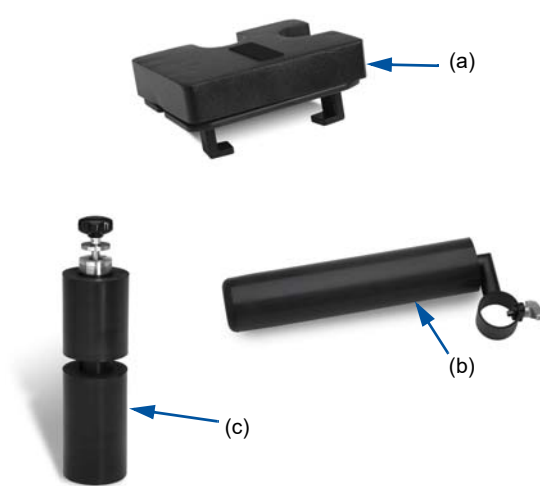

**Table 7: Standard Components**

Component	Description
<p><b>Hana® Table Base</b></p>  <p><b>REF 6875-326 110V (6875)</b>  <b>REF 6875-326I 220-230V (6875I)</b>  <b>REF 6875-326J 100V (6875J)</b></p>	<p>The Hana® Table Base consists of the base of the table, the Motion Control Box, and tabletop. It also includes the Hana® Hand Pendant, Jack Mount Assembly, Main Table Pad, and Pelvic Pad.</p> <p>There are three versions of the Hana® Table Base to accommodate different regional voltage requirements.</p>
<p><b>REF 6807-4 Hana® Hand Pendant (replacement part)</b></p> 	<p>The Hana® Hand Pendant controls the Hana® Table functions, including table top height, Trendelenburg/Reverse Trendelenburg angle, and lateral tilt angle. It also provides AC power and battery status information.</p>

**Table 7: Standard Components** (Continued)

Component	Description
<p><b>REF 6875-7120 Hana® Main Table Pad (replacement part)</b></p> 	<p>The 2-inch (5 cm) Hana® Main Table Pad is of TEMPUR® construction. Velcro® secures the pad to the tabletop. Align the Velcro® on the bottom of the pad with the Velcro® on the tabletop when installing.</p>
<p><b>REF 6875-7129 Hana® Pelvic Pad (replacement part)</b></p> 	<p>The 2-inch (5 cm) Hana® Pelvic Pad is of TEMPUR® construction. It attaches to the Foot-End of the table top and supports the patient's pelvis when positioned supine on the Hana® Table.</p>
<p><b>REF 6850-413 Adult Perineal Post</b></p> 	<p>The Adult Perineal Post provides counter-traction, while the urethane foam pad helps relieve pressure on the perineal area. The Adult Perineal Post is 9 inches long (22.8 cm) and has a 2.75-inch (7 cm) diameter with pad.</p> <p>Disposable blue foam perineal post covers are available (see Section 7.2).</p>

**Table 7: Standard Components** *(Continued)*

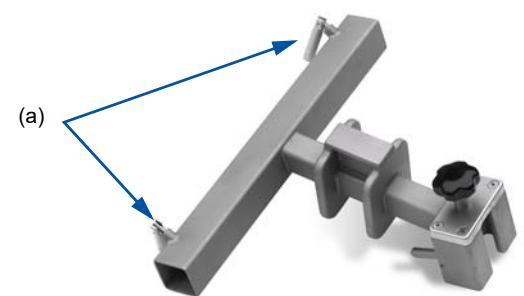



Component	Description
<p><b>REF 6875-250 Lateral Perineal Post and Board</b></p>  <p>(a) <b>REF 5855-309 Lateral Pad Assembly</b>                  (b) <b>REF 5855-137 Lateral Perineal Post Assembly</b>                  (c) <b>REF 5855-242 Ilium Post Assembly</b></p>	<p>The Lateral Perineal Post provides counter-traction when the patient is in the lateral decubitus position. The padded board supports the patient's pelvis when in the lateral decubitus position on the Hana® Table.</p>
<p><b>REF 5840-44 Patient Safety Strap</b></p> 	<p>The Patient Safety Strap secures the patient in place when positioned on the table. The 90-inch strap slides around the Foot-End of the table.</p>
<p><b>REF 6875-2730 Jack Mount Assembly (replacement part)</b></p>  <p>(a) <b>REF 914-516 Drop Handle</b></p>	<p>The Jack Mount Assembly attaches to underside of the tabletop, and supports the left and right Femur Lifts and the optional Hana® Patient Transfer Board. It may be easily removed when not in use to improve C-arm access.</p>

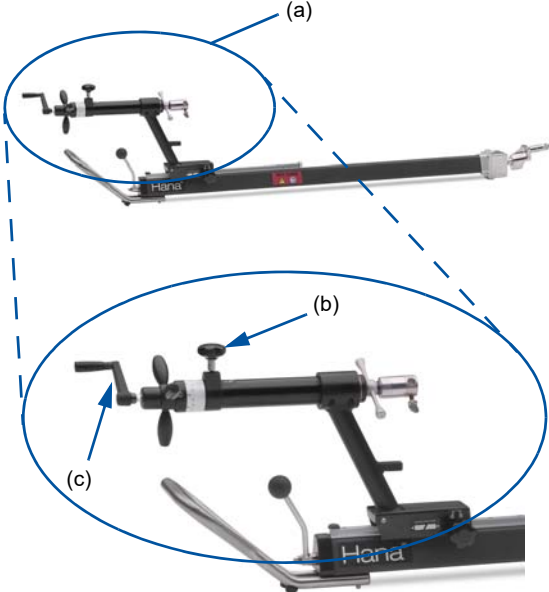

**Table 7: Standard Components** (Continued)

Component	Description
<p><b>REF 6875-292 Hana® Arm Board (2)</b></p>  <p><b>(a) REF 6850-7600 Arm Board Pad</b></p>	<p>The Hana® Arm Boards provide support for the patient's arms when positioned supine on the Hana® Table. When the patient is positioned laterally on the Hana® Table, one Hana® Arm Board may be used in conjunction with the optional Cross Arm Support to support patient's arms.</p> <p>The Hana® Arm Board comes with a one-inch (2.5 cm) Tempur-Pedic® Medical Pad.</p> <p>A variety of disposable foam padding options for the Hana® Arm Boards are available (see Section 7.2).</p>
<p><b>Hana® Radiolucent Leg Spars (Left and Right)</b></p>  <p><b>REF 6875-390 Left</b> (Backwards compatible with <b>REF 6875-360</b>)</p> <p><b>REF 6875-370 Right</b> (Backwards compatible with <b>REF 6875-350</b>)</p> <p><b>(a) REF 6875-2370 Traction Unit Assembly</b></p> <p><b>(b) REF 6875-378 Foot Rotation Locking Knob</b></p> <p><b>(c) REF 6850-313 Fine Traction Crank Handle</b></p>	<p>The Left and Right Hana® Radiolucent Leg Spars attach to the Foot-End of the table and support the patient's legs while in supine or lateral decubitus positions.</p> <p>The Leg Spars allow for traction, abduction, adduction, and raising or lowering of the leg.</p>



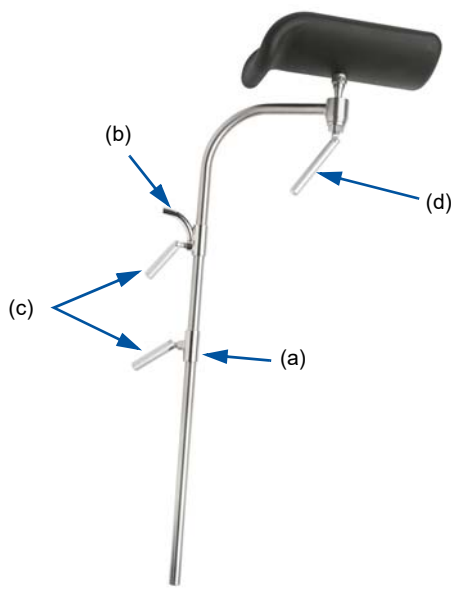
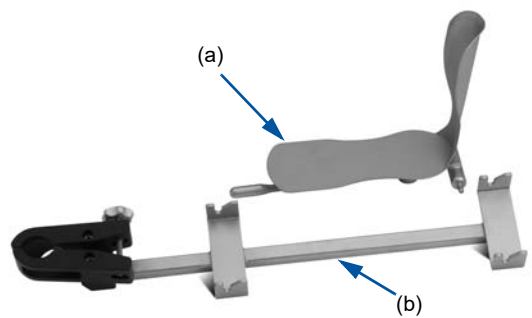

**Table 7: Standard Components** (Continued)

Component	Description
<p><b>Traction Boots (Pair)</b></p>  <p>REF 6850-486 Large Pair REF 6850-485 Small Pair REF FE00386 Boot Liners, Large Pair REF FE00384 Boot Liners, Small Pair</p>	<p>The Traction Boots secure the patient's feet to the Leg Spars for procedures requiring skin traction. One (1) small pair and one (1) large pair come standard with the Hana® Table. An optional Extra-Large size is also available (see Section 9).</p> <p>The standard black boot liners can be replaced. In addition, disposable boot liners are available (see Section 7.2).</p>
<p>REF 6875-399 Traction Hook Extender</p> 	<p>The Traction Hook Extender connects the Traction Boot to the Traction Unit of the Leg Spar for patients who are short in stature.</p>
<p>REF 6875-200 Well Leg Support Adapter</p> 	<p>The Well Leg Support Adapter attaches to the table, and allows mounting of the Articulating Bracket and Well Leg Support Assembly, which can be used to support the patient's non-operative leg while in the supine position.</p>
<p>REF 6300-92 Articulating Bracket</p> 	<p>The Articulating Bracket attaches to the Well Leg Support Adapter and provides the point of attachment for the Well Leg Support Assembly. The bracket is adjustable, enhancing positioning options for the Well Leg Support Assembly.</p>





**Table 7: Standard Components** (Continued)

Component	Description
<p><b>REF 5855-838 Well Leg Support Assembly</b></p>  <p>(a) <b>REF 5855-423 Collar Assembly</b>                  (b) <b>REF 5855-424 Collar with Hook</b>                  (c) <b>REF 914-416 Drop Handle Assembly</b>                  (d) <b>REF 5300-52 Drop Handle Assembly</b></p>	<p>The Well Leg Support Assembly attaches to the table through the use of the Well Leg Support Adapter and Articulating Bracket. It can be used to support the patient's non-operative leg while in the supine position.</p>
<p><b>REF 6875-230 Hana® Knee Flexion System®</b></p>  <p>(a) <b>REF 6875-209 Knee Flexion Footplate Assembly</b>                  (b) <b>REF 6875-208 Knee Flexion Base Assembly</b></p>	<p>The Hana® Knee Flexion System® is designed to mount on the operative Leg Spar to support and position the leg as needed during Total Knee Arthroplasty (TKA). It allows for full flexion/extension of the leg and knee as well as internal/external rotation of the foot.</p>

**Table 7: Standard Components** (Continued)

Component	Description
<p><b>Femur Lift Assembly (Left and Right)</b></p>  <p><b>REF 6875-600 Right</b> <b>REF 6875-601 Left</b></p>	<p>The Femur Lift Assemblies raise and lower the operative side Femoral Hook and Femoral Hook Support for use during Anterior Approach Total Hip Arthroplasty. The Femur Lift Assemblies may also be used to support the optional Lateral Perineal Post, used during IM Tibial Nailing (see Section 9.4).</p>
<p><b>REF 6875-264 Femur Lift Extension (2)</b></p> 	<p>The Femur Lift Extension attaches to either the left or right Femur Lift. It provides the attachment point for the Femoral Hook Support.</p>
<p><b>REF 6875-602 Femur Lift Emergency Crank Handle</b></p> 	<p>The Femur Lift Emergency Crank Handle attaches to the rear of the Femur Lift Assembly. It provides a manual method for raising and lowering the Femur Lift if there is a loss of power.</p>
<p><b>REF 6875-5003 Hana® Femur Lift Foot Pedal</b></p> 	<p>The Femur Lift Foot Pedal operates both left and right Femur Lifts. It plugs into the port at the Foot-End of the table base.</p>

**Table 7: Standard Components** (Continued)

Component	Description
<p><b>REF 6850-110 Femoral Hook Support (2)</b></p> 	<p>The Femoral Hook Support mounts on the Femur Lift Extension. It provides eight notches for insertion of the Femoral Hook. This allows flexibility in positioning to accommodate the size of the patient.</p>
<p><b>Femoral Hooks, Left and Right</b></p>  <p><b>REF 6850-918 Right</b> <b>REF 6850-919 Left</b></p>	<p>Two (2) Femoral Hooks come standard with the Hana® Table: one left and one right. The Femoral Hook is used during Anterior Approach Total Hip Arthroplasty. It inserts into one of the eight notches on the Femoral Hook Support.</p> <p>The choice of Femoral Hook or Classic Femoral Hook is at the discretion of the surgeon and surgical team.</p>
<p><b>Classic Femoral Hooks, Left and Right</b></p>  <p><b>REF 6850-140 Classic Left</b> <b>REF 6850-144 Classic Right</b></p>	<p>Two (2) Classic Femoral Hooks come standard with the Hana® Table: one left and one right. The Femoral Hook is used during Anterior Approach Total Hip Arthroplasty. It inserts into one of the eight notches on the Femoral Hook Support.</p> <p>The choice of Femoral Hook or Classic Femoral Hook is at the discretion of the surgeon and surgical team.</p>
<p><b>REF 6875-20 Hana® Table Cover</b></p> 	<p>The Hana® Table Cover serves as a dust cover when the table is in storage.</p>

**Table 7: Standard Components** *(Continued)*

Component	Description
<p><b>REF 6855-3 Hana® Patient Care Kit</b></p> 	<p>The Patient Care Kits are single-use padding and covers intended to prevent cross-contamination and protect the equipment. Three (3) Patient Care Kits are included with the Hana® Table. See Section 7.3 for reordering information.</p>

## 7.2 Disposable Components











To place an order for disposable components, contact Mizuho OSI Sales Operations at 1-800-777-4674 within the USA or +1-510-429-1500 outside the USA. At the prompt, select Option 1.



**WARNING: Disposable components are single use only. Discard after use. Re-use of any disposable component may result in cross-contamination.**

Refer to the following table when ordering any disposable components for the Hana® Orthopedic Surgery Table:

**Table 8: Disposable Components**

<p><b>REF 5855-18 Soft Traction Boot Liners, Small</b> (24 per case)</p> <p><b>REF 5855-17 Soft Traction Boot Liners, Large</b> (24 per case)</p> 	<p><b>REF 5937DZ Disposable Boot Liners</b> (12 per case) – good for all sizes of Traction Boots</p> 	<p><b>REF 6855-13 Perineal Post Cover, Blue Foam</b> (12 per case)</p> 
<p><b>REF 5929DZ Perineal Post Cover, 6-inch</b> (12 per case)</p> 	<p><b>REF 5823-10 Foam Arm Cradles</b> (6 pairs per case)</p> 	<p><b>REF 5932 NervPro® System, Ulnar Protective Pads</b> (6 per case)</p> 
<p><b>REF 1901-12 Convoluted Foam Pads</b> (12 pairs per case)</p> 	<p><b>REF 370 Convoluted Foam Padding</b> (6" x 24" x 2")</p> 	<p><b>REF 1902-20 Supine/Lateral Head Rest</b> (20 per case)</p> 
<p><b>REF 1921 9" Headrest Donut</b></p> <p><b>REF 1922 7" Headrest Donut</b></p> 	<p><b>REF 5858 Patient Isolation Drape</b> (12 per case)</p>	

### 7.3 Hana® Patient Care Kits

Each individual Hana® Patient Care Kit includes the following:

- Supine/Lateral Headrest
- Leg Spar Ball Joint Protector (2)
- Adjustable Arm Board Pad (2)
- 27-inch Arm Board Strap
- Perineal Post Cover



**WARNING: Patient Care Kits are single-use-only. Discard after use. Re-use of any component in the Patient Care Kit may result in cross-contamination.**

The components should be used as described in the Patient Care Kit  Instructions for Use, which are included in each packaged kit. The Hana® Orthopedic Surgery Table ships with three (3) individual Hana® Patient Care Kits. A case of six (6) individual kits is provided when ordering **REF** 6855.

**NOTE:** *Remove the Patient Care Kit components from the packaging and visually inspect the components.*



## 8 Surgical Procedure Setups

---



**CAUTION:** Inspect all components and accessories for signs of wear or damage before installing on the table.



**CAUTION:** When applying safety straps, monitor patient contact points for pressure points that could cause circulatory or other impairment.

Instructions provided are for suggested setups. Final determination of patient positioning and setup is at the discretion of the surgeon and surgical team.

**NOTE:** For the following setups, use Patient Care Kit components as described in  Instructions for Use included in each Kit. A variety of additional soft goods are also available for use in all setups to ensure optimal patient comfort. For more information, see Section 7.2 and Section 7.3. Final determination of products used is at the discretion of the surgeon and surgical team.

**NOTE:** The following setup instructions make use of many standard components and optional accessories. For more detailed information on installing and adjusting standard components, see Section 6. For more detailed information on installing and adjusting optional accessories, see Section 9.

## 8.1 IM Femoral Nailing: Unilateral Skeletal Traction

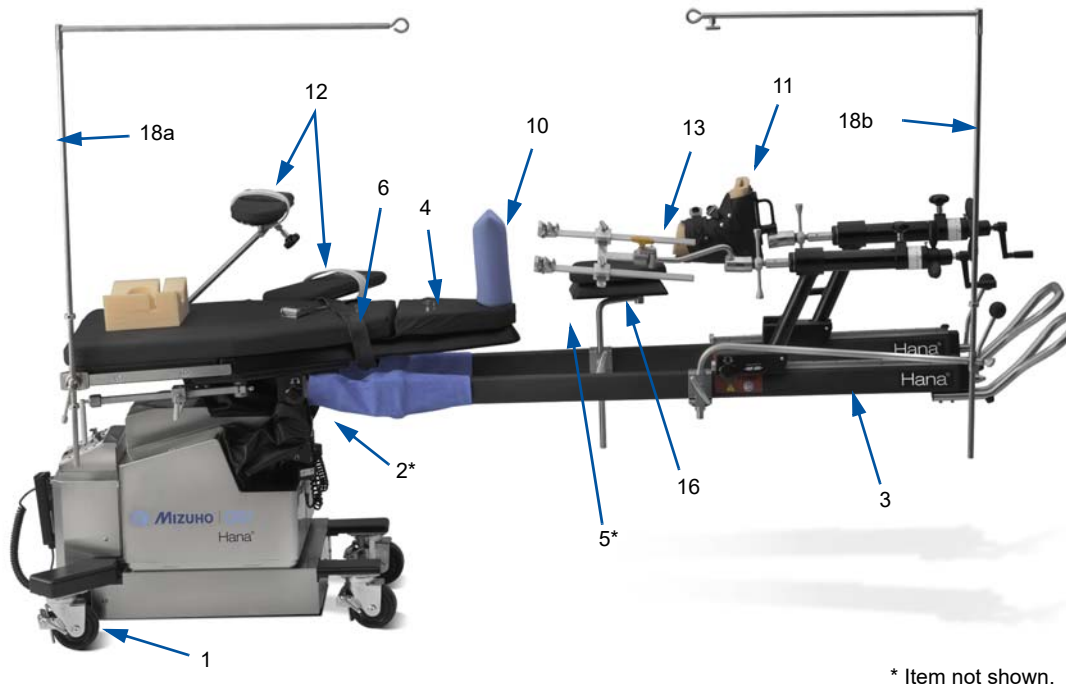

\* Item not shown.

**Figure 58: Table Setup for Right IM Femoral Nailing, Supine, with Skeletal Traction**

**NOTE:** Each number in the setup image identifies the component(s) described in the corresponding step in the following setup instructions.

1. Ensure all four (4) Casters are in the locked position.
2. If the optional Hana® Patient Transfer Board is to be used, ensure that the Jack Mount Assembly is installed.
3. Attach both the left and right Hana® Radiolucent Leg Spars to the table and lock in place.
4. Place the Pelvic Pad on the table.
5. Attach the optional Hana® Patient Transfer Board.
6. Slide the Patient Safety Strap into place.
7. Adjust the table to the appropriate height for patient transfer from the stretcher.
8. Put the appropriate size Traction Boot (small, large, or optional extra-large) on the patient's non-operative foot while the patient is on the stretcher.
9. Transfer the patient to the table in the supine position and secure with the Patient Safety Strap.
10. Insert the padded Perineal Post into the table. Move the patient to establish firm contact with the Perineal Post and adjust the Patient Safety Strap as appropriate.

11. Attach the Traction Boot on the non-operative leg to the Traction Mount on the non-operative Leg Spar.

**NOTE:** *If the patient is short in stature and the Traction Brake Cover enters the Red Zone, the installation and use of the Traction Hook Extender is required. See Section 6.6 for more information.*

12. Install a Hana® Arm Board with pad to both left and right sides of the table and position the patient's arms out to the side, or attach one Hana® Arm Board with pad and the optional Cross Arm Support using a Clark Socket to the non-operative side of the table. Secure the patient's arms.

13. Attach the Traction Device Hook to the Leg Spar Traction Mount. If desired, the optional 90 Degree Pin and Wire Holder or Kirschner Bow Holder may be used instead. They require attaching a ProFx® Traction Boot Adapter Assembly to the Leg Spar Traction Mount. Position the patient's operative leg.

**NOTE:** *If the patient is short in stature and the Traction Brake Cover enters the Red Zone, the installation and use of the Traction Hook Extender is required. See Section 6.6 for more information.*

14. Secure the patient's operative foot directly to the Leg Spar.

15. Remove the optional Patient Transfer Board by sliding it out from underneath the fully positioned patient.



16. If desired, attach the optional Lower Leg Support to the non-operative leg spar with an Accessory Clamp and lock it into place.

17. Trial position the C-arm unit on the non-operative side.

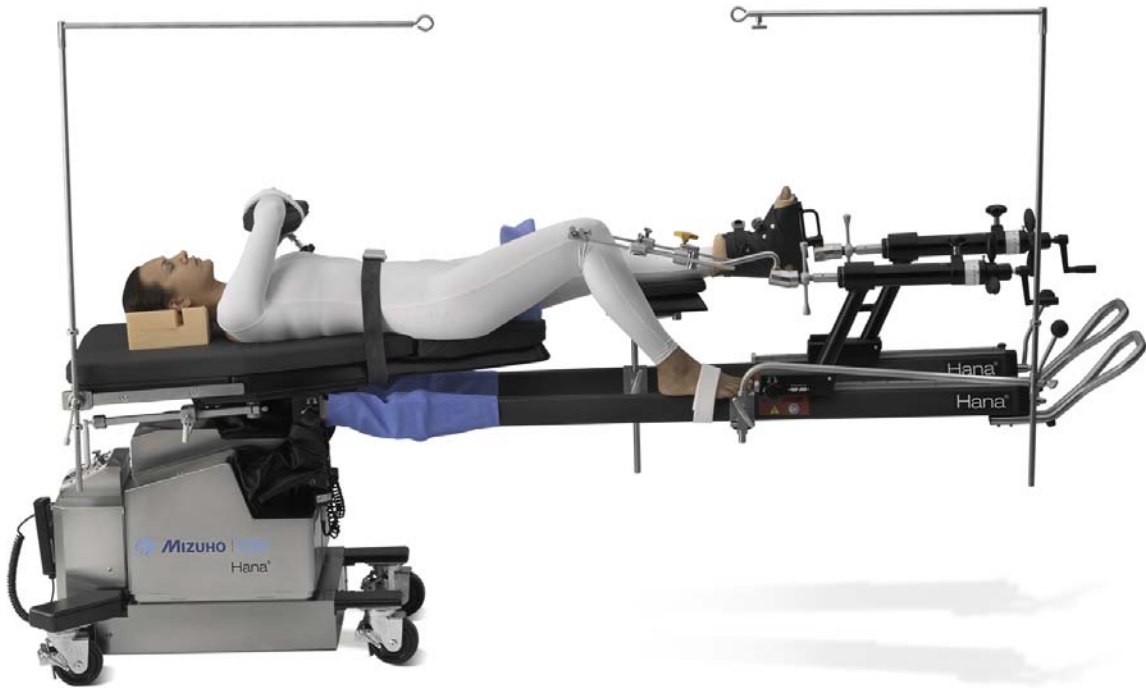
18. If desired install the optional Head-End and Foot-End Drape Rod Assemblies, and suspend the Patient Isolation Drapes.

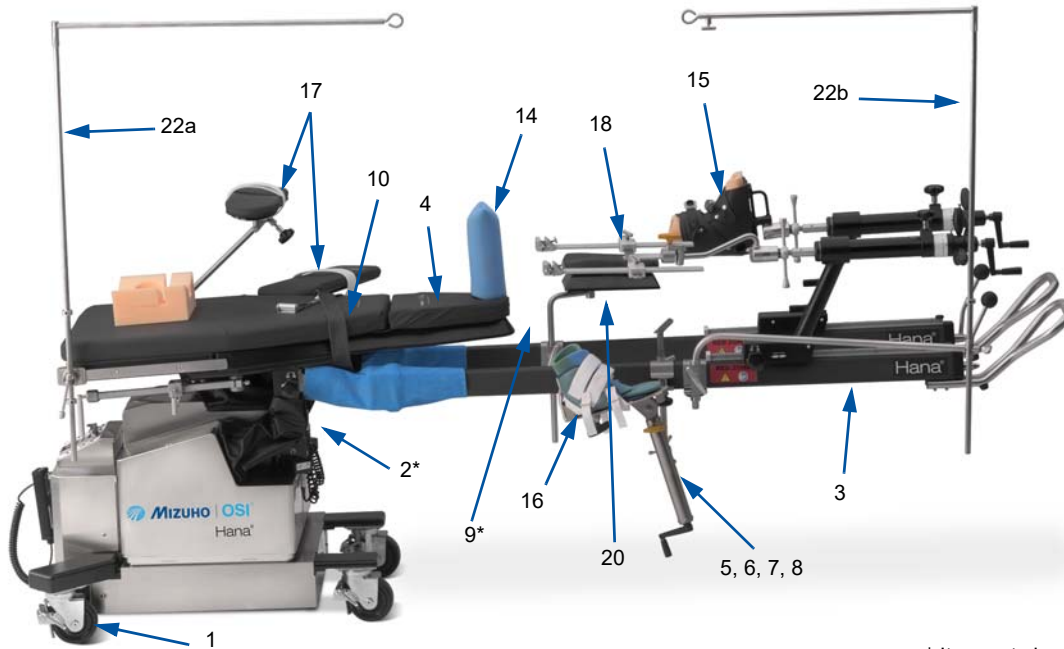

**Figure 59: Patient Positioned for Right IM Femoral Nailing, Supine, with Skeletal Traction (Foot Secured to Leg Spar)**

Components for Femur Nailing, Supine with Skeletal Traction		
<p>Jack Mount Assembly</p> 	<p>Hana® Radiolucent Leg Spar, Left and Right</p> 	<p>Pelvic Pad</p> 
<p>Hana® Patient Transfer Board (Optional)</p> 	<p>Patient Safety Strap</p> 	<p>Traction Boot (Left or Right), Large or Small</p> 

Components for Femur Nailing, Supine with Skeletal Traction <i>(Continued)</i>		
<p>Perineal Post</p> 	<p>Traction Hook Extender (1 or 2)</p> 	<p>Hana® Arm Board with Pad (1 or 2)</p> 
<p>Cross Arm Support <i>(Optional)</i></p> 	<p>Clark Socket <i>(Optional)</i></p> 	<p>Traction Device Hook <i>(Optional)</i></p> 
<p>90 Degree Pin and Wire Holder <i>(Optional)</i></p> 	<p>Kirschner Bow Holder <i>(Optional)</i></p> 	<p>ProFx® Traction Boot Adapter Assembly <i>(Optional)</i></p> 
<p>Lower Leg Support <i>(Optional)</i></p> 	<p>Accessory Clamp <i>(Optional)</i></p> 	<p>Head-End Drape Rod Assembly <i>(Optional)</i></p> 
<p>Foot-End Drape Rod Assembly <i>(Optional)</i></p> 		

## 8.2 IM Femoral Nailing: Unilateral Skeletal Traction (with Traction Foot Plate Assembly)



\* Item not shown.

**Figure 60: Table Setup for Right IM Femoral Nailing, Supine, with Skeletal Traction (with Traction Foot Plate Assembly)**

**NOTE:** Each number in the setup image identifies the component(s) described in the corresponding step in the following setup instructions.









1. Ensure all four (4) Casters are in the locked position.
2. If the optional Hana® Patient Transfer Board is to be used, ensure that the Jack Mount Assembly is installed.
3. Attach both the left and right Hana® Radiolucent Leg Spars to the table and lock in place.
4. Place the Pelvic Pad on the table.
5. Attach an Accessory Clamp to the operative-side Leg Spar near the Foot-End with the receiver on the non-operative side of the table.
6. Insert the optional Tibia Traction Upright into the Accessory Clamp from the bottom with the Traction Unit Receiver facing the operative side of the table.
7. Attach the optional Traction Unit to the Tibia Traction Upright.
8. Attach the optional Traction Foot Plate Assembly to the Traction Unit.

**NOTE:** If desired, the operative foot can be secured to the Traction Unit in a Traction Boot instead of using the Traction Foot Plate Assembly. In this instance, attach a Tibial Traction Boot Adapter to the Traction Unit.









9. Attach the optional Hana® Patient Transfer Board.
  10. Slide the Patient Safety Strap into place.
  11. Adjust the table to the appropriate height for patient transfer from the stretcher.
  12. Put the appropriate size Traction Boot (small, large, or optional extra-large) on the patient's non-operative foot while the patient is on the stretcher.
- NOTE:** *If using a Traction Boot instead of the Traction Foot Plate Assembly, put a second Traction Boot on the patient's operative foot.*
13. Transfer the patient to the table in the supine position and secure with the Patient Safety Strap.
  14. Insert the padded Perineal Post into the table. Move the patient to establish firm contact with the Perineal Post and adjust the Patient Safety Strap as appropriate.
  15. Attach the Traction Boot on the non-operative leg to the Traction Mount on the non-operative Leg Spar.
- NOTE:** *If the patient is short in stature and the Traction Brake Cover enters the Red Zone, the installation and use of the Traction Hook Extender is required. See Section 6.6 for more information.*
16. Secure the operative foot to the Traction Foot Plate Assembly.
- NOTE:** *If using a Traction Boot on the operative foot instead, attach the Traction Boot to the Tibial Traction Boot Adapter mounted on the Traction Unit.*
17. Install a Hana® Arm Board with pad to both left and right sides of the table and position the patient's arms out to the side, or attach one Hana® Arm Board with pad and the optional Cross Arm Support using a Clark Socket to the non-operative side of the table. Secure the patient's arms.
  18. Attach the Traction Device Hook to the Leg Spar Traction Mount. If desired, the optional 90 Degree Pin and Wire Holder or Kirschner Bow Holder may be used instead. They require attaching a ProFx® Traction Boot Adapter Assembly to the Leg Spar Traction Mount. Position the patient's operative leg.
- NOTE:** *If the patient is short in stature and the Traction Brake Cover enters the Red Zone, the installation and use of the Traction Hook Extender is required. See Section 6.6 for more information.*
19. Remove the optional Hana® Patient Transfer Board by sliding it out from underneath the fully positioned patient.
  20. If desired, attach the optional Lower Leg Support to the non-operative leg spar with an Accessory Clamp and lock it into place.
  21. Trial position the C-arm unit on the non-operative side.
  22. If desired install the optional Head-End and Foot-End Drape Rod Assemblies, and suspend the Patient Isolation Drapes.



**Figure 61: Patient Positioned for Right IM Femoral Nailing, Supine, with Skeletal Traction (Foot Secured to Optional Traction Foot Plate Assembly)**

Components for Femur Nailing, Supine with Skeletal Traction		
<p>Jack Mount Assembly</p> 	<p>Hana® Radiolucent Leg Spar, Left and Right</p> 	<p>Pelvic Pad</p> 
<p>Accessory Clamp (Optional)</p> 	<p>Tibial Traction Upright (Optional)</p> 	<p>Traction Unit (Optional)</p> 
<p>Traction Foot Plate Assembly (Optional)</p> 	<p>Tibial Traction Boot Adapter (Optional)</p> 	<p>Hana® Patient Transfer Board (Optional)</p> 



Components for Femur Nailing, Supine with Skeletal Traction <i>(Continued)</i>		
<p>Patient Safety Strap</p> 	<p>Traction Boot (Left or Right), Large or Small</p> 	<p>Perineal Post</p> 
<p>Traction Hook Extender (1 or 2)</p> 	<p>Hana® Arm Board with Pad (2)</p> 	<p>Cross Arm Support <i>(Optional)</i></p> 
<p>Clark Socket <i>(Optional)</i></p> 	<p>Traction Device Hook <i>(Optional)</i></p> 	<p>90 Degree Pin and Wire Holder <i>(Optional)</i></p> 
<p>Kirschner Bow Holder <i>(Optional)</i></p> 	<p>ProFx® Traction Boot Adapter Assembly <i>(Optional)</i></p> 	<p>Lower Leg Support <i>(Optional)</i></p> 
<p>Head-End Drape Rod Assembly <i>(Optional)</i></p> 	<p>Foot-End Drape Rod Assembly <i>(Optional)</i></p> 	

### 8.3 IM Femoral Nailing: Unilateral Skin Traction

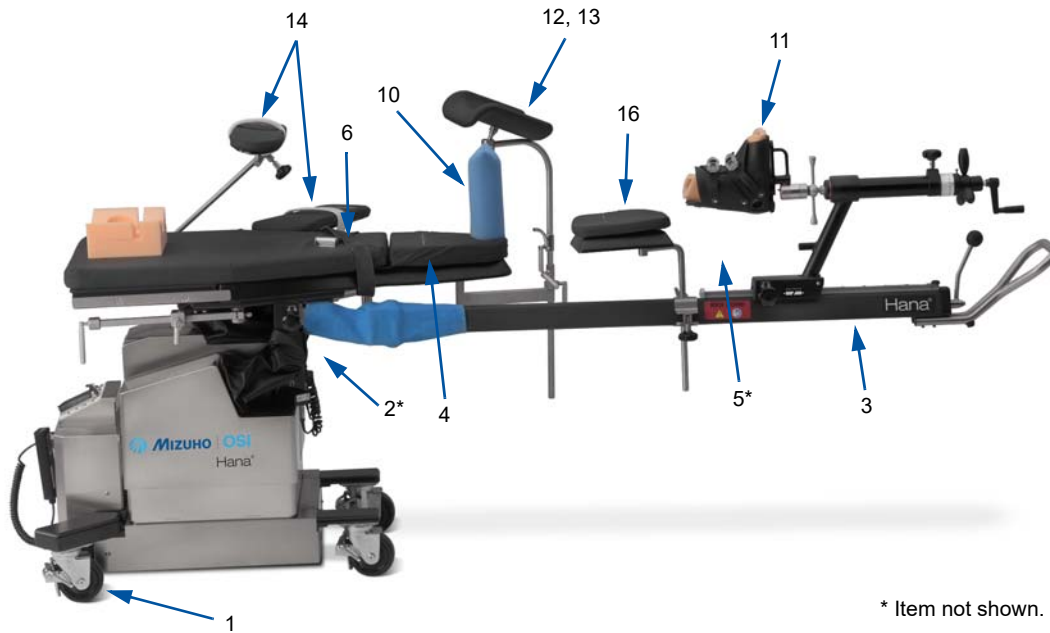

**Figure 62: Table Setup for Right IM Femoral Nailing, Supine, with Unilateral Skin Traction**

**NOTE:** Each number in the setup image identifies the component(s) described in the corresponding step in the following setup instructions.

1. Ensure all four (4) Casters are in the locked position.
2. If the optional Hana® Patient Transfer Board is to be used, ensure that the Jack Mount Assembly is installed.
3. Attach the appropriate left or right Hana® Radiolucent Leg Spar to the table on the operative side and lock in place.
4. Place the Pelvic Pad on the table.
5. Attach the optional Hana® Patient Transfer Board.
6. Slide the Patient Safety Strap into place.
7. Adjust the table to the appropriate height for patient transfer from the stretcher.
8. Put the appropriate size Traction Boot (small, large, or optional extra-large) on the patient's operative foot while the patient is on the stretcher.
9. Transfer the patient to the table in the supine position and secure with the Patient Safety Strap.
10. Insert the padded Perineal Post into the table. Move the patient to establish firm contact with the Perineal Post and adjust the Patient Safety Strap as appropriate.
11. Attach the Traction Boot to the Traction Mount on the Leg Spar.

**NOTE:** *If the patient is short in stature and the Traction Brake Cover enters the Red Zone, the installation and use of the Traction Hook Extender is required. See Section 6.6 for more information.*

12. Attach the Well Leg Support Adapter to the Spar Mount on the non-operative side of the table and lock into position.
13. Attach the Well Leg Support Assembly to the Well Leg Support Adapter using the Articulating Bracket and secure the patient's non-operative leg.
14. Install a Hana® Arm Board with pad to both left and right sides of the table and position the patient's arms out to the side, or attach one Hana® Arm Board with pad and the optional Cross Arm Support using a Clark Socket to the non-operative side of the table. Secure the patient's arms.
15. Remove the optional Hana® Patient Transfer Board by sliding it out from underneath the fully positioned patient.
16. If desired, attach the optional Lower Leg Support to the Leg Spar with an Accessory Clamp and lock it into place. Pad and secure the patient's operative leg.
17. Trial-position the C-arm unit on the non-operative side.
18. If desired, install the optional Head-End and Foot-End Drape Rod Assemblies and suspend the Patient Isolation Drapes.



**Figure 63: Patient Positioned for Right IM Femoral Nailing, Supine, with Unilateral Skin Traction**

Components for Femur Nailing Supine with Skin Traction		
<p>Jack Mount Assembly</p> 	<p>Hana® Radiolucent Leg Spar, Left and Right</p> 	<p>Pelvic Pad</p> 
<p>Hana® Patient Transfer Board (Optional)</p> 	<p>Patient Safety Strap</p> 	<p>Traction Boot (Left or Right), Large or Small</p> 
<p>Perineal Post</p> 	<p>Traction Hook Extender</p> 	<p>Well Leg Support Adapter</p> 
<p>Articulating Bracket</p> 	<p>Well Leg Support Assembly</p> 	<p>Hana® Arm Board with Pad (1 or 2)</p> 
<p>Cross Arm Support (Optional)</p> 	<p>Clark Socket (Optional)</p> 	<p>Lower Leg Support (Optional)</p> 
<p>Accessory Clamp (Optional)</p> 	<p>Head-End Drape Rod Assembly (Optional)</p> 	<p>Foot-End Drape Rod Assembly (Optional)</p> 

## 8.4 IM Femoral Nailing: Lateral Decubitus Position with Bilateral Skin Traction

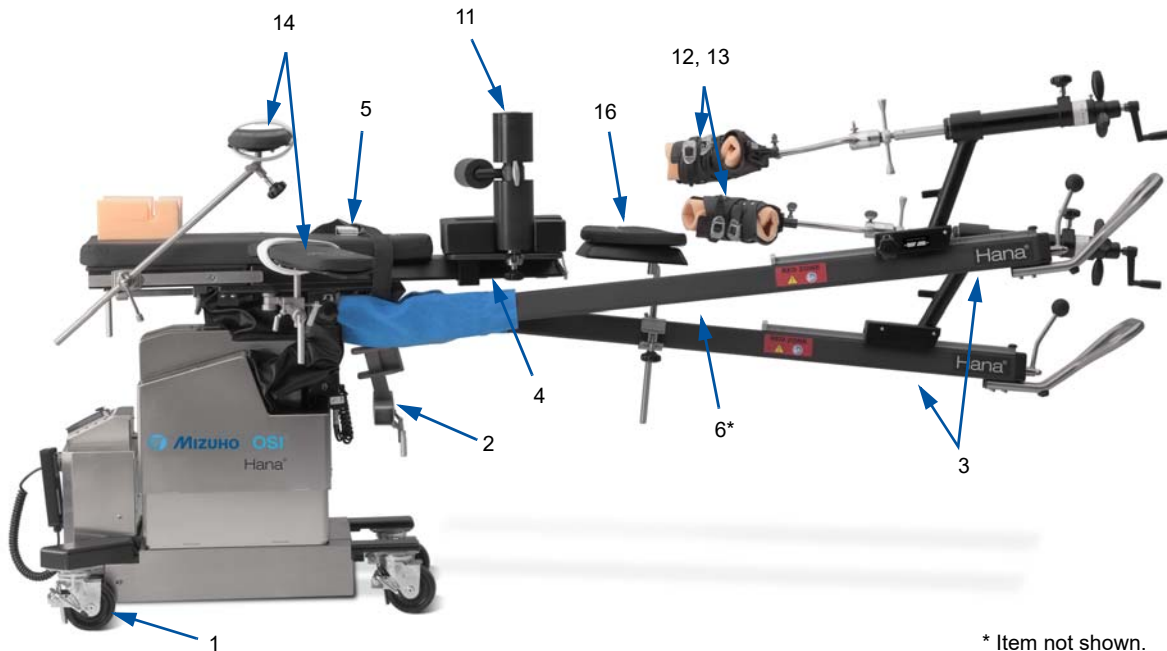

**Figure 64: Table Setup for IM Femoral Nailing, Lateral Decubitus Position with Bilateral Skin Traction**

**NOTE:** Each number in the setup image identifies the component(s) described in the corresponding step in the following setup instructions.

1. Ensure all four (4) Casters are in the locked position.
2. If the optional Hana® Patient Transfer Board is to be used, ensure that the Jack Mount Assembly is installed.
3. Attach both the left and right Hana® Radiolucent Leg Spars to the table and lock in place.
4. Attach the Lateral Board Assembly (without Lateral Perineal Post) to the table top by sliding it into position and inserting the plug into the standard Perineal Post hole on the table top.
5. Slide the Patient Safety Strap into place.
6. Attach the optional Hana® Patient Transfer Board.
7. Adjust the table to the appropriate height for patient transfer from the stretcher.
8. Put the appropriate size Traction Boots (small, large, or optional extra-large) on the patient's feet and secure while the patient is on the stretcher.
9. Transfer the patient to the table in the supine position.

10. Reposition patient into the lateral decubitus position. At this time, an attendant should be assigned to support the patient until patient is safely positioned and secured.
11. Install the Lateral Perineal Post. Slide the patient toward the Foot-End of the table until firmly positioned against the Perineal Post and secure with the Patient Safety Strap.
12. Attach the Traction Boot on the patient's non-operative side to the Traction Mount on the operative side Leg Spar.
13. Attach the Traction Boot on the patient's operative side to the Traction Mount on the non-operative side Leg Spar.

**NOTE:** *If the patient is short in stature and the Traction Brake Cover enters the Red Zone, the installation and use of the Traction Hook Extender is required. See Section 6.6 for more information.*

14. Install a Hana® Arm Board with pad and optional Cross Arm Support using a Clark Socket to the non-operative side of the table and secure the patient's arms.
15. Remove the optional Hana® Patient Transfer Board by sliding it out from underneath the fully positioned patient.
16. Attach the optional Lower Leg Support to the lower Leg Spar using an Accessory Clamp. Pad and secure the patient's non-operative leg.
17. If desired, install the optional Head-End and Foot-End Drape Rod Assemblies, and suspend the Patient Isolation Drapes.



**Figure 65: Patient Positioned for IM Femoral Nailing, Lateral Decubitus Position with Bilateral Skin Traction**

Components for IM Femur Nailing, Lateral Decubitus Position with Bilateral Skin Traction		
<p>Jack Mount Assembly</p> 	<p>Hana® Radiolucent Leg Spar, Left and Right</p> 	<p>Lateral Perineal Post and Board Assembly</p> 
<p>Patient Safety Strap</p> 	<p>Hana® Patient Transfer Board (Optional)</p> 	<p>Traction Boot (Pair), Large or Small</p> 
<p>Traction Hook Extender</p> 	<p>Hana® Arm Board with Pad</p> 	<p>Cross Arm Support (Optional)</p> 
<p>Clark Socket (Optional)</p> 	<p>Lower Leg Support (Optional)</p> 	<p>Accessory Clamp (Optional)</p> 
<p>Head-End Drape Rod Assembly (Optional)</p> 	<p>Foot-End Drape Rod Assembly (Optional)</p> 	

## 8.5 IM Tibial Nailing: Supine with Unilateral Skin Traction

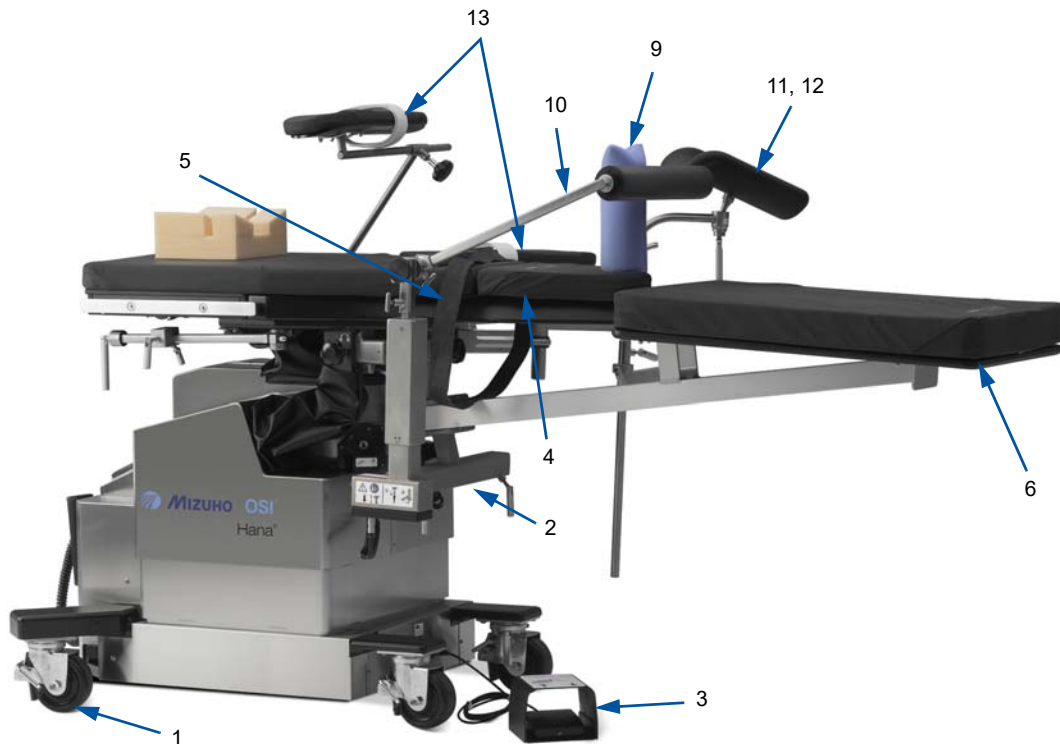

**Figure 66: Table Setup for Right IM Tibial Nailing, Supine Position with Unilateral Skin Traction**

**NOTE:** Each number in the setup image identifies the component(s) described in the corresponding step in the following setup instructions.

1. Ensure all four (4) Casters are in the locked position.
2. Ensure that the Jack Mount Assembly is installed. Attach the appropriate Femur Lift Assembly (right or left) to the operative side of the table.
3. Plug the Femur Lift Foot Pedal into the front of the base of the table. Ensure that the Femur Lift Assembly is in its lowest position.
4. Place the Pelvic Pad on the table.
5. Slide the Patient Safety Strap in place.
6. Attach the optional Hana® Patient Transfer Board.
7. Adjust the table to the appropriate height for patient transfer from the stretcher.
8. Transfer the patient to the table in the supine position and secure with the Patient Safety Strap.
9. Insert the padded Perineal Post into the table. Move the patient to establish firm contact with the Perineal Post and adjust the Patient Safety Strap as appropriate.



10. Attach the optional Lateral Perineal Post to the Femur Lift Assembly using the Mount Bracket for the Lateral Perineal Post and position the patient's leg over the Lateral Perineal Post.



**WARNING:** It is important that the Lateral Perineal Post be placed against the distal femur, two to three inches proximal to the popliteal fossa. Placement of the post into the fossa may result in a potential neurological or circulatory injury.

11. Attach the Well Leg Support Adapter to the Leg Spar Mount on the non-operative side of the table and lock into position.
12. Attach the Well Leg Support Assembly to the Well Leg Support Adapter using the Articulating Bracket and secure the patient's non-operative leg.
13. Install a Hana® Arm Board with pad to both left and right sides of the table and position patient's arms out to the side, or attach one Hana® Arm Board with Pad and the optional Cross Arm Support using a Clark Socket to the non-operative side of the table, and secure the patient's arms.
14. Remove the optional Hana® Patient Transfer Board by sliding it out from underneath the fully positioned patient.
15. Trial position the C-arm unit.



**Figure 67: Patient Positioned for Right IM Tibia Nailing, Supine Position with Unilateral Skin Traction**

Components for IM Tibia Nailing, in Supine Position with Unilateral Skin Traction		
<p>Jack Mount Assembly</p> 	<p>Femur Lift Assembly (Left or Right)</p> 	<p>Femur Lift Foot Pedal</p> 
<p>Pelvic Pad</p> 	<p>Patient Safety Strap</p> 	<p>Hana® Patient Transfer Board <i>(Optional)</i></p> 
<p>Perineal Post</p> 	<p>Lateral Perineal Post <i>(Optional)</i></p> 	<p>Lateral Perineal Post Adapter <i>(Optional)</i></p> 
<p>Well Leg Support Adapter</p> 	<p>Well Leg Support Assembly</p> 	<p>Articulating Bracket</p> 
<p>Hana® Arm Board with Pad (1 or 2)</p> 	<p>Cross Arm Support <i>(Optional)</i></p> 	<p>Clark Socket <i>(Optional)</i></p> 

## 8.6 Retrograde IM Femoral Nailing: Supine with Unilateral Skin Traction

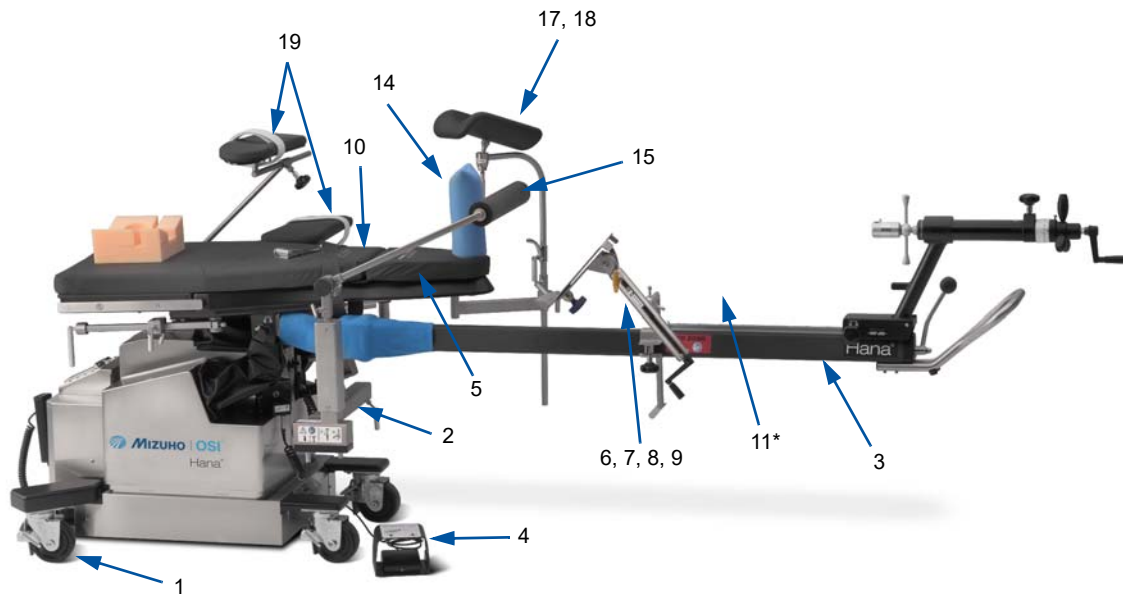

\* Item not shown.

**Figure 68: Table Setup for Retrograde IM Femoral Nailing, Supine Position with Unilateral Skin Traction**

**NOTE:** Each number in the setup image identifies the component(s) described in the corresponding step in the following setup instructions.

1. Ensure all four (4) Casters are in the locked position.
2. Ensure that the Jack Mount Assembly is installed. Attach the appropriate Femur Lift Assembly (right or left) to the operative side of the table.
3. Attach the appropriate left or right Hana® Radiolucent Leg Spar on the operative side of the table and lock in place.
4. Plug the Femur Lift Foot Pedal into the front of the base of the table. Ensure that the Femur Lift Assembly is in its lowest position.
5. Place the Pelvic Pad on the table.
6. Attach an Accessory Clamp to the operative side Leg Spar near the Foot-End with the receiver on the non-operative side of the table.
7. Insert the Tibial Traction Unit Upright into the Accessory Clamp from the bottom with the Traction Unit Receiver facing the operative side of the table.
8. Attach the Traction Unit to the Tibial Traction Upright.
9. Attach the Traction Foot Plate Assembly to the Traction Unit.
10. Slide the Patient Safety Strap in place.

11. Attach the optional Hana® Patient Transfer Board.
12. Adjust the table to the appropriate height for patient transfer from the stretcher.
13. Transfer the patient to the table in the supine position and secure with the Patient Safety Strap.
14. Insert the padded Perineal Post into the table. Move the patient to establish firm contact with the Perineal Post and adjust the Patient Safety Strap as appropriate.
15. Attach the optional Lateral Perineal Post to the Femur Lift Assembly using the Mount Bracket for the Lateral Perineal Post and position the patient's leg over the Lateral Perineal Post.



**WARNING:** It is important that the Lateral Perineal Post be placed against the distal femur, two to three inches proximal to the popliteal fossa. Placement of the post into the fossa may result in a potential neurological or circulatory injury.

16. Secure the patient's operative foot to the Traction Foot Plate Assembly.

**NOTE:** *Before making any height adjustments to the Lateral Perineal Post using the Femur Lift Assembly, be sure to remove the operative foot from the Traction Foot Plate Assembly. Once height adjustments have been made, re-secure the foot to the Traction Foot Plate Assembly.*

17. Attach the Well Leg Support Adapter to the Leg Spar Mount on the non-operative side of the table and lock into position.
18. Attach the Well Leg Support Assembly to the Well Leg Support Adapter using the Articulating Bracket and secure the patient's non-operative leg.
19. Install a Hana® Arm Board with pad to both left and right sides of the table and position patient's arms out to the side, or attach one Hana® Arm Board with Pad and the optional Cross Arm Support using a Clark Socket to the non-operative side of the table, and secure the patient's arms.
20. Remove the optional Hana® Patient Transfer Board by sliding it out from underneath the fully positioned patient.
21. Trial position the C-arm unit.

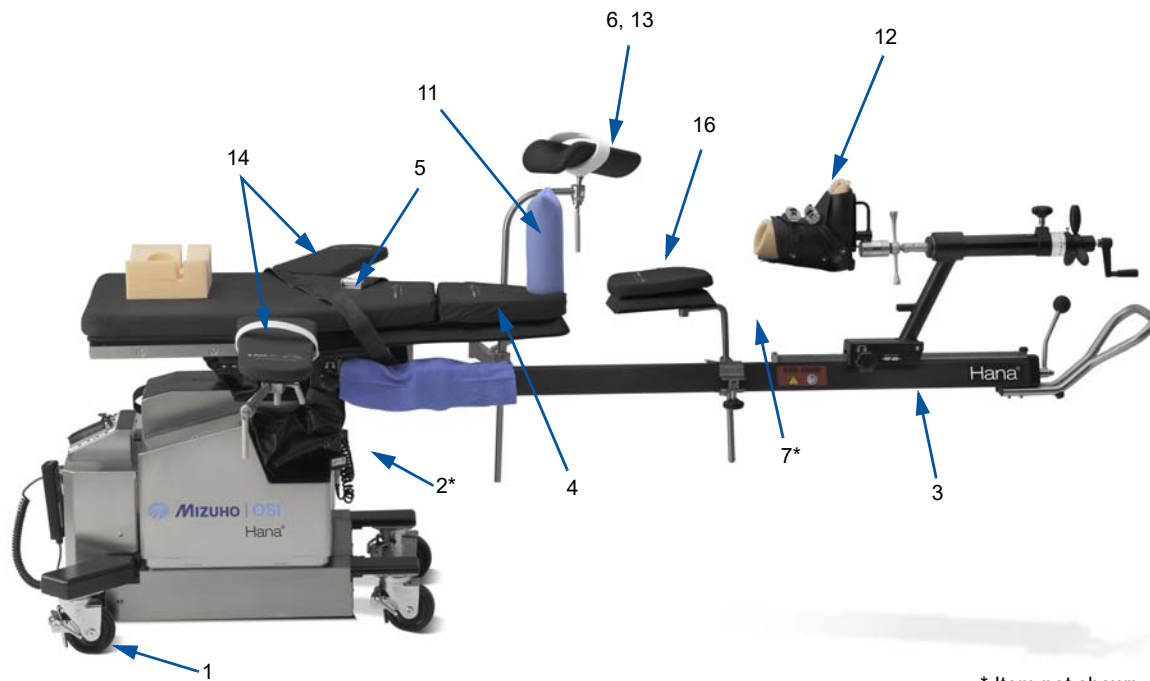

**Figure 69: Patient Positioned for Retrograde IM Femoral Nailing, Supine Position with Unilateral Skin Traction**

Components for Retrograde IM Femoral Nailing, Supine with Unilateral Skin Traction		
<p>Jack Mount Assembly</p> 	<p>Hana® Radiolucent Leg Spar, Left and Right</p> 	<p>Femur Lift Assembly (Left or Right)</p> 
<p>Femur Lift Foot Pedal</p> 	<p>Pelvic Pad</p> 	<p>Accessory Clamp (Optional)</p> 
<p>Tibial Traction Upright (Optional)</p> 	<p>Traction Unit (Optional)</p> 	<p>Traction Foot Plate Assembly (Optional)</p> 

Components for Retrograde IM Femoral Nailing, Supine with Unilateral Skin Traction <i>(Continued)</i>		
<p>Patient Safety Strap</p> 	<p>Hana® Patient Transfer Board <i>(Optional)</i></p> 	<p>Perineal Post</p> 
<p>Lateral Perineal Post <i>(Optional)</i></p> 	<p>Lateral Perineal Post Adapter <i>(Optional)</i></p> 	<p>Well Leg Support Adapter</p> 
<p>Well Leg Support Assembly</p> 	<p>Articulating Bracket</p> 	<p>Hana® Arm Board with Pad (1 or 2)</p> 
<p>Cross Arm Support <i>(Optional)</i></p> 	<p>Clark Socket <i>(Optional)</i></p> 	

## 8.7 Hip Pinning: Supine With Unilateral Skin Traction



\* Item not shown.

**Figure 70: Table Setup for Right Hip Pinning, Supine Position with Unilateral Skin Traction**

**NOTE:** Each number in the setup image identifies the component(s) described in the corresponding step in the following setup instructions.

1. Ensure all four (4) Casters are in the locked position.
2. If the optional Hana® Patient Transfer Board is to be used, ensure that the Jack Mount Assembly is installed.
3. Attach the operative side Hana® Radiolucent Leg Spar (left or right) to the table and lock in place.
4. Place the Pelvic Pad on the table.
5. Slide the Patient Safety Strap in place.
6. Attach the Well Leg Support Adapter into the Leg Spar Mount on the non-operative side of the table and lock into position.
7. Attach the optional Hana® Patient Transfer Board.
8. Adjust the table to the appropriate height for patient transfer from the stretcher.
9. Put the appropriate size Traction Boot (small, large, or optional extra-large) on the patient's operative foot while the patient is on the stretcher.
10. Transfer the patient to the table in the supine position.

11. Insert the padded Perineal Post, move the patient to establish firm contact with the Perineal Post, and then secure the patient with the Patient Safety Strap.
  12. Place the Traction Boot on the patient's operative foot into the traction mount on the operative side Leg Spar.
- NOTE:** *If the patient is short in stature and the Traction Brake Cover enters the Red Zone, the installation and use of the Traction Hook Extender is required. See Section 6.6 for more information.*
13. Attach the Well Leg Support Assembly to the Well Leg Support Adapter using the Articulating Bracket, and secure the patient's non-operative leg.
  14. Install a Hana® Arm Board with pad to both right and left sides of the table and position the patient's arms out to the side, or attach one Hana® Arm Board with pad and the optional Cross Arm Support using a Clark Socket to the non-operative side of the table. Secure the patient's arms.
  15. Remove the optional Hana® Patient Transfer Board by sliding it out from underneath the fully positioned patient.
  16. If desired, attach the optional Lower Leg Support to the Leg Spar with an Accessory Clamp and lock it into place. Pad and secure the patient's operative leg.
  17. If desired, install the optional Head-End and Foot-End Drape Rod Assemblies, and suspend the Patient Isolation Drapes.

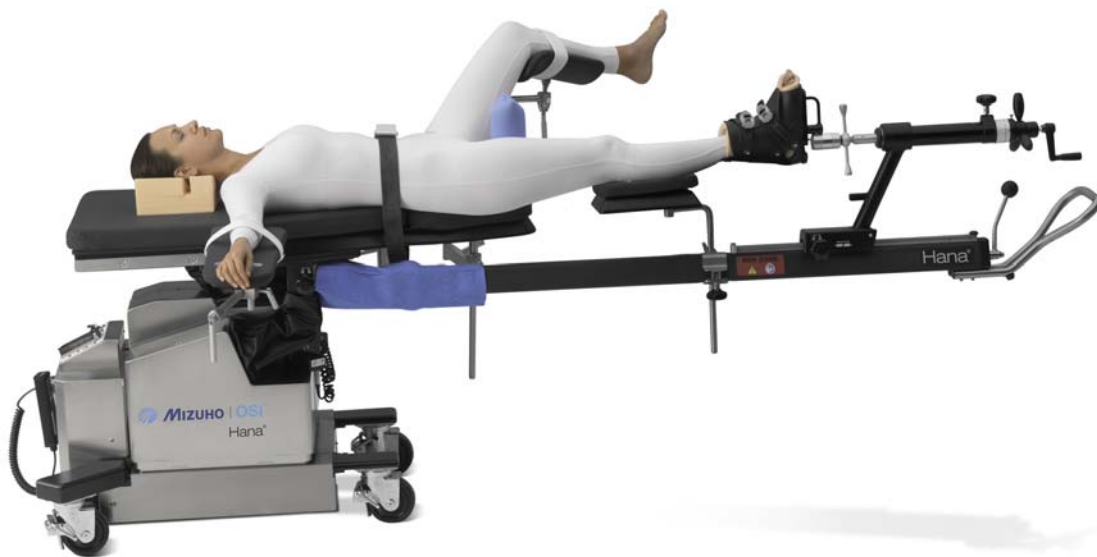
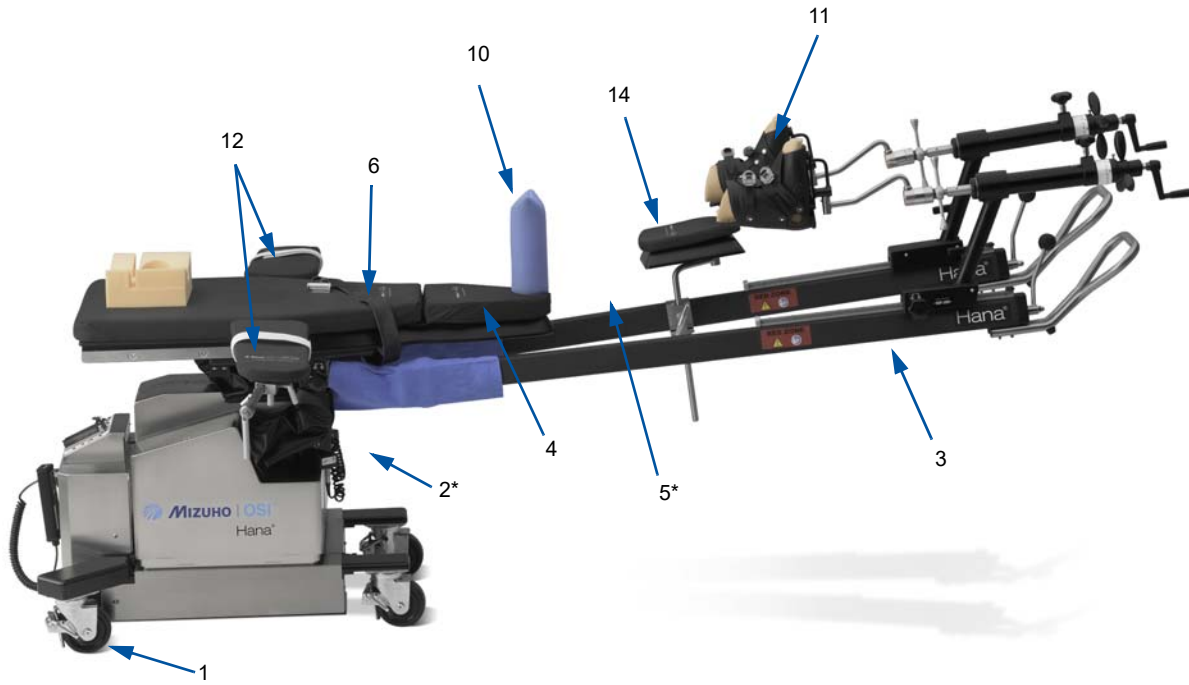

**Figure 71: Patient Positioned for Right Hip Pinning, Supine Position with Unilateral Skin Traction**



Components for Hip Pinning, Supine Position with Unilateral Skin Traction		
<p>Jack Mount Assembly</p> 	<p>Hana® Radiolucent Leg Spar, Left or Right</p> 	<p>Pelvic Pad</p> 
<p>Patient Safety Strap</p> 	<p>Well Leg Support Adapter</p> 	<p>Hana® Patient Transfer Board (Optional)</p> 
<p>Traction Boot (Left or Right), Large or Small</p> 	<p>Perineal Post</p> 	<p>Traction Hook Extender</p> 
<p>Well Leg Support Assembly</p> 	<p>Articulating Bracket</p> 	<p>Hana® Arm Board with Pad (1 or 2)</p> 
<p>Cross Arm Support (Optional)</p> 	<p>Clark Socket</p> 	<p>Lower Leg Support (Optional)</p> 
<p>Accessory Clamp (Optional)</p> 	<p>Head-End Drape Rod Assembly (Optional)</p> 	<p>Foot-End Drape Rod Assembly (Optional)</p> 

## 8.8 Hip Pinning: Supine With Bilateral Skin Traction



\* Item not shown.

**Figure 72: Table Setup for Hip Pinning with Bilateral Skin Traction, Supine Position**

**NOTE:** Each number in the setup image identifies the component(s) described in the corresponding step in the following setup instructions.

1. Ensure all four (4) Casters are in the locked position.
2. If the optional Hana® Patient Transfer Board is to be used, ensure that the Jack Mount Assembly is installed.
3. Attach both left and right Hana® Radiolucent Leg Spars to the table and lock in place.
4. Place the Pelvic Pad on the table.
5. Attach the optional Hana® Patient Transfer Board.
6. Slide the Patient Safety Strap in place.
7. Adjust the table to the appropriate height for patient transfer from the stretcher.
8. Put the appropriate size Traction Boots (small, large, or optional extra-large) on the patient's feet while the patient is on the stretcher.
9. Transfer the patient to the table in the supine position.
10. Insert the padded Perineal Post, move the patient to establish firm contact with the Perineal Post, and then secure with the Patient Safety Strap.

11. Attach the Traction Boots to the Leg Spar Traction Mounts and lock in place.

**NOTE:** *If the patient is short in stature and the Traction Brake Cover enters the Red Zone, the installation and use of the Traction Hook Extender is required. See Section 6.6 for more information.*

12. Install a Hana® Arm Board with pad to both right and left sides of the table and position the patient's arms out to the side, or attach one Hana® Arm Board with pad and the optional Cross Arm Support using a Clark Socket to the non-operative side of the table. Secure the patient's arms.

13. Remove the optional Hana® Patient Transfer Board by sliding it out from underneath the fully positioned patient.

14. If desired, attach the optional Lower Leg Support to the operative or non-operative Leg Spar using an Accessory Clamp and lock in place.

15. Trial position the C-Arm.

16. If desired, install the optional Head-End and Foot-End Drape Rod Assemblies, and suspend the Patient Isolation Drapes.



**Figure 73: Patient Positioned for Hip Pinning, Supine, with Bilateral Skin Traction**

Components for Hip Pinning, Supine, with Bilateral Skin Traction		
<p>Jack Mount Assembly</p> 	<p>Hana® Radiolucent Leg Spar, Left and Right</p> 	<p>Pelvic Pad</p> 
<p>Hana® Patient Transfer Board (Optional)</p> 	<p>Patient Safety Strap</p> 	<p>Traction Boot (Pair), Large or Small</p> 
<p>Perineal Post</p> 	<p>Traction Hook Extender</p> 	<p>Hana® Arm Board with Pad (1 or 2)</p> 
<p>Cross Arm Support (Optional)</p> 	<p>Clark Socket (Optional)</p> 	<p>Lower Leg Support (Optional)</p> 
<p>Accessory Clamp (Optional)</p> 	<p>Head-End Drape Rod Assembly (Optional)</p> 	<p>Foot-End Drape Rod Assembly (Optional)</p> 

## 8.9 Anterior Approach Total Hip Arthroplasty

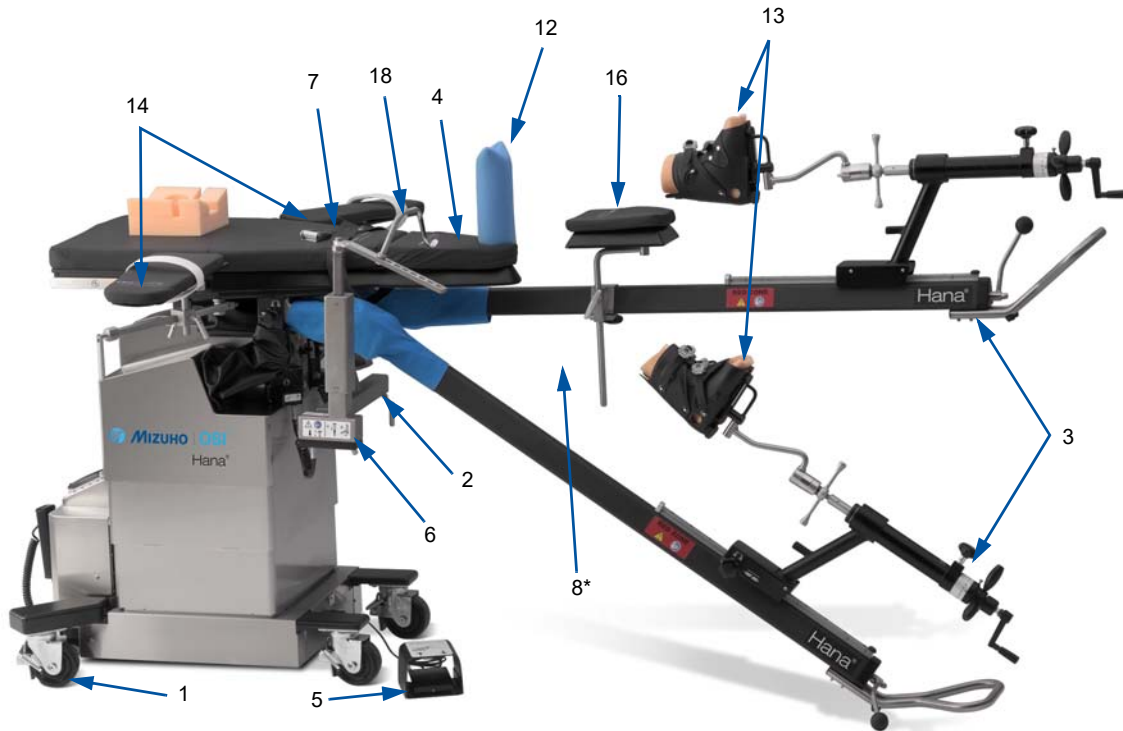

\* Item not shown.

**Figure 74: Table Setup for Anterior Approach Right Total Hip Arthroplasty**

**NOTE:** Each number in the setup image identifies the component(s) described in the corresponding step in the following setup instructions.

**NOTE:** Femoral Hook Support Assembly and appropriate Femoral Hook need to be sterilized before use during the surgery (see Section 10.2). These items attach to the top of the appropriate Femur Lift Assembly.

1. Ensure all four (4) Casters are in the locked position.
2. Ensure that the Jack Mount Assembly is installed.
3. Ensure that both the left and right Hana® Radiolucent Leg Spars are attached to the table and locked in place.
4. Place the Pelvic Pad on the table.
5. Plug the Femur Lift Foot Pedal into the front of the base of the table.
6. Insert the appropriate Femur Lift Assembly (left or right) on the operative side of the table and attach the Coiled Hook Motor Cable. Using the Foot Pedal, adjust the Femur Lift Assembly to its lowest position.

7. Slide the Patient Safety Strap in place.
  8. Attach the optional Hana® Patient Transfer Board.
  9. Adjust the table to the appropriate height for patient transfer from the stretcher.
  10. Put the appropriate size Traction Boots (large, small, or optional extra-large) on the patient's feet while the patient is on the stretcher.
  11. Transfer the patient to the table in the supine position.
  12. Insert the padded Perineal Post. Move the patient to establish firm contact with the Perineal Post and secure with the Patient Safety Strap.
  13. Attach the Traction Boots to the appropriate Traction Mount on the Leg Spars.
- NOTE:** *If the patient is short in stature and the Traction Brake Cover enters the Red Zone, the installation and use of the Traction Hook Extender is required. See Section 6.6 for more information.*
14. Install a Hana® Arm Board with pad to both left and right sides of the table and position the patient's arms out to the side, or attach one Hana® Arm Board with pad and the optional Cross Arm Support using a Clark Socket to the non-operative side of the table. Secure the patient's arms.
  15. Remove the optional Hana® Patient Transfer Board by sliding it out from underneath the fully positioned patient.
  16. If desired, attach the optional Lower Leg Support to the non-operative Leg Spar using an Accessory Clamp and lock in place. Secure the patient's non-operative leg.
  17. Trial position the C-arm unit on the non-operative side of table.
  18. Attach sterilized Femoral Hook Support and Femoral Hook during surgical procedure.



**Figure 75: Patient Positioned for Anterior Approach Right Total Hip Replacement**

Components for Anterior Approach Total Hip Replacement		
<p>Jack Mount Assembly</p> 	<p>Hana® Radiolucent Leg Spar, Left and Right</p> 	<p>Pelvic Pad</p> 
<p>Femur Lift Foot Pedal</p> 	<p>Femur Lift Assembly</p> 	<p>Patient Safety Strap</p> 
<p>Hana® Patient Transfer Board <i>(Optional)</i></p> 	<p>Traction Boot (Pair), Large or Small</p> 	<p>Perineal Post</p> 
<p>Traction Hook Extender (2)</p> 	<p>Hana® Arm Board with Pad (2)</p> 	<p>Cross Arm Support <i>(Optional)</i></p> 
<p>Clark Socket <i>(Optional)</i></p> 	<p>Lower Leg Support <i>(Optional)</i></p> 	<p>Accessory Clamp <i>(Optional)</i></p> 
<p>Femoral Hook Support</p> 	<p>Femoral Hooks</p> 	

## 8.10 Hip Arthroscopy

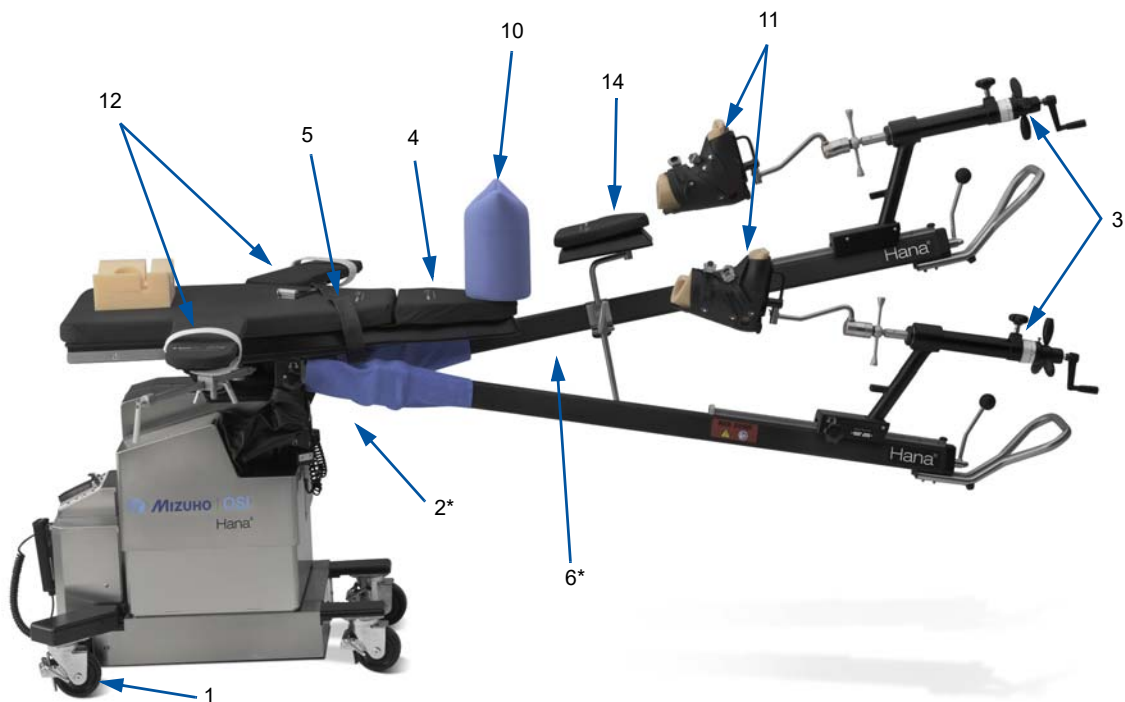

\* Item not shown.

**Figure 76: Table Setup for Hip Arthroscopy**

**NOTE:** Each number in the setup image identifies the component(s) described in the corresponding step in the following setup instructions.

1. Ensure all four (4) Casters are in the locked position.
2. If the optional Hana® Patient Transfer Board is to be used, ensure that the Jack Mount Assembly is installed.
3. Ensure that both the left and right Hana® Radiolucent Leg Spars are attached to the table and locked in place.

**NOTE:** Optionally, the non-operative leg may be supported using the Well Leg Support Assembly instead of the Hana® Radiolucent Leg Spar.

4. Place the Pelvic Pad on the table.
5. Slide the Patient Safety Strap in place.
6. Attach the optional Hana® Patient Transfer Board.
7. Adjust the table to the appropriate height for patient transfer from the stretcher.
8. Put the appropriate size Traction Boots (large, small, or optional extra-large) on the patient's feet while the patient is on the stretcher.



**NOTE:** *If the Well Leg Support Assembly is being used, do not put a Traction Boot on the non-operative foot.*

9. Transfer the patient to the table in the supine position.
10. Insert the Large Diameter Perineal Post. Move the patient to establish firm contact with the Perineal Post and secure with the Patient Safety Strap.
11. Attach the Traction Boots to the appropriate Traction Mount on the Leg Spars.

**NOTE:** *If the patient is short in stature and the Traction Brake Cover enters the Red Zone, the installation and use of the Traction Hook Extender is required. See Section 6.6 for more information.*

12. Install a Hana® Arm Board with pad to both left and right sides of the table and position the patient's arms out to the side, or attach one Hana® Arm Board with pad and the optional Cross Arm Support using a Clark Socket to the non-operative side of the table. Secure the patient's arms.
13. Remove the optional Hana® Patient Transfer Board by sliding it out from underneath the fully positioned patient.
14. If desired, attach the optional Lower Leg Support to the non-operative Leg Spar using an Accessory Clamp and lock in place. Secure the patient's non-operative leg.
15. Trial position the C-arm unit on the non-operative side of the table.



**Figure 77: Patient Positioned for Hip Arthroscopy**

Components for Hip Arthroscopy		
<p>Jack Mount Assembly</p> 	<p>Hana® Radiolucent Leg Spar, Left and Right</p> 	<p>Pelvic Pad</p> 
<p>Patient Safety Strap</p> 	<p>Hana® Patient Transfer Board (Optional)</p> 	<p>Traction Boot (Pair), Large or Small</p> 
<p>Large Diameter Perineal Post</p> 	<p>Traction Hook Extender (2)</p> 	<p>Hana® Arm Board with Pad (2)</p> 
<p>Cross Arm Support (Optional)</p> 	<p>Clark Socket (Optional)</p> 	<p>Lower Leg Support (Optional)</p> 
<p>Accessory Clamp (Optional)</p> 		

## 8.11 Total Knee Arthroplasty (with Well Leg Support Assembly)

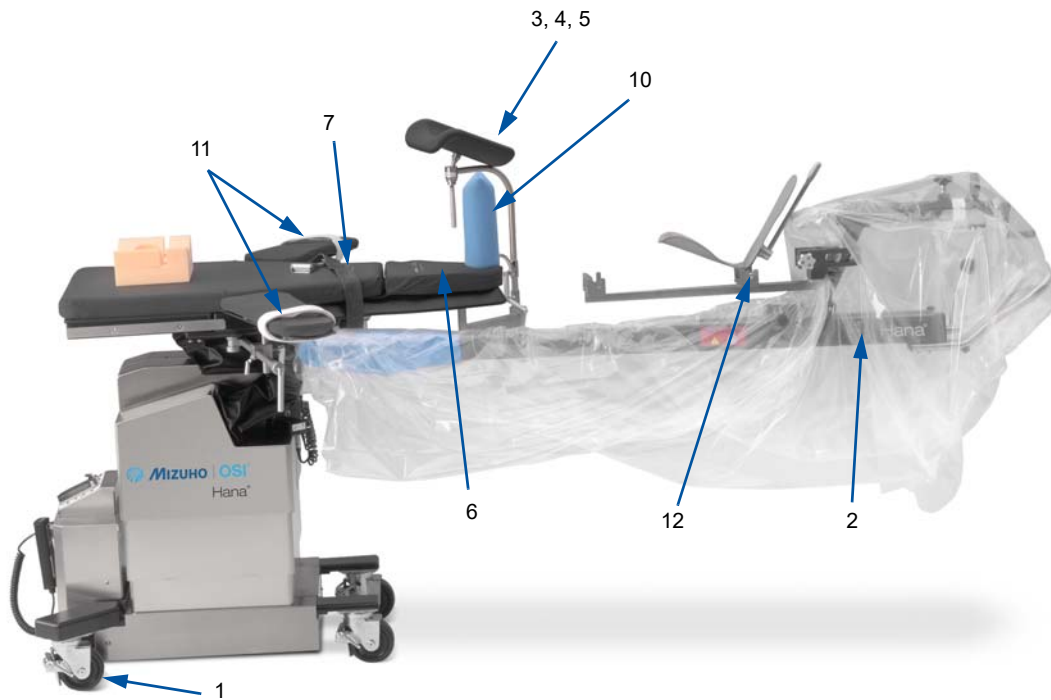

**Figure 78: Table Setup for Total Knee Arthroplasty (with Well Leg Support Assembly)**

**NOTE:** Each number in the setup image identifies the component(s) described in the corresponding step in the following setup instructions.

**NOTE:** The Knee Flexion System® must be sterilized before use in surgery (see Section 10.2).

1. Ensure all four (4) Casters are in the locked position.
2. If not already in place, attach the appropriate left or right Hana® Radiolucent Leg Spar to the operative side of the table and lock in place.
3. Attach the Well Leg Support Adapter to the non-operative side of the table and lock in place.
4. Attach the Articulating Bracket to the Well Leg Support Adapter and tighten securely.
5. Insert the Well Leg Support Assembly into the Articulating Bracket and tighten securely.
6. Place the Pelvic Pad on the table. If extra support is desired, slide the Lateral Board Assembly (without Lateral Perineal Post) on the table instead.
7. Slide the Patient Safety Strap in place.
8. Adjust the table to the appropriate height for patient transfer from the stretcher.
9. Transfer the patient to the table in the supine position, place the non-operative leg in the Well Leg Support Assembly, and then secure the patient with Patient Safety Strap.
10. Insert the padded Perineal Post into the table. Move the patient to establish firm contact with the Perineal Post and adjust the Patient Safety Strap as appropriate.

11. Install a Hana® Arm Board with pad to both left and right sides of the table and position the patient's arms out to the side. Secure the patient's arms.
12. Drape the operative side Hana® Radiolucent Leg Spar and attach the sterilized Knee Flexion System® to the Leg Spar.
13. Place the operative foot on the Foot Plate of the Knee Flexion System® and secure according to surgeon protocol.

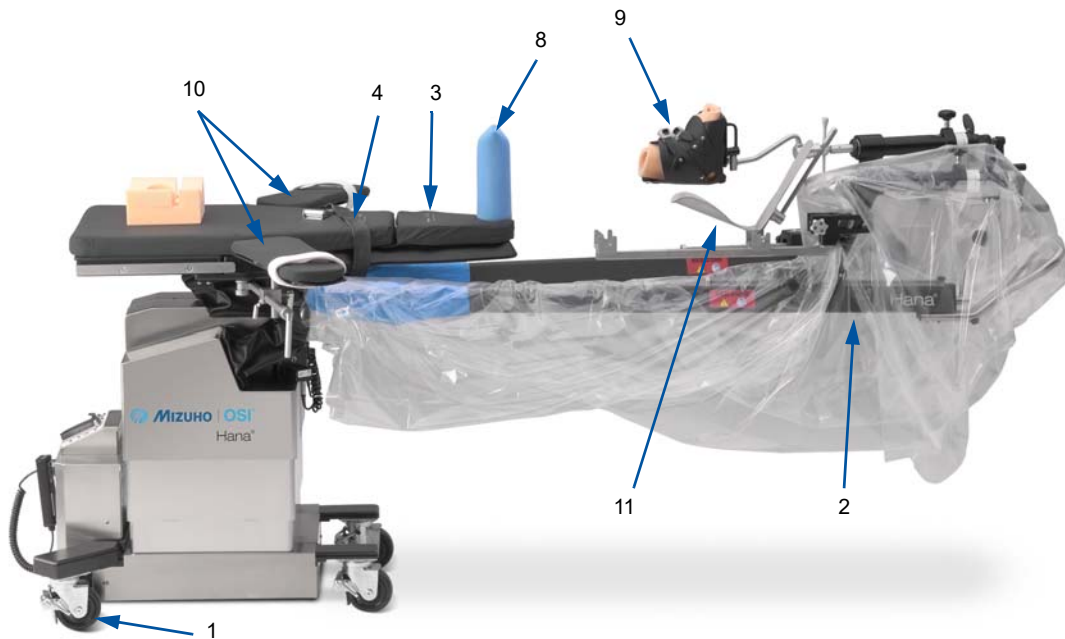

**Figure 79: Patient Positioned for Total Knee Arthroplasty (with Well Leg Support Assembly)**

Components for Total Knee Arthroplasty, with Well Leg Support Assembly		
<p>Hana® Radiolucent Leg Spar, Left or Right</p> 	<p>Well Leg Support Adapter</p> 	<p>Articulating Bracket</p> 
<p>Well Leg Support Assembly</p> 	<p>Pelvic Pad</p> 	<p>Lateral Board</p> 

Components for Total Knee Arthroplasty, with Well Leg Support Assembly (Continued)		
<p>Patient Safety Strap</p> 	<p>Perineal Post</p> 	<p>Hana® Arm Board with Pad (2)</p> 
<p>Hana® Knee Flexion System®</p> 		

## 8.12 Total Knee Arthroplasty (with Left and Right Leg Spars)



**Figure 80: Table Setup for Total Knee Arthroplasty (with Left and Right Leg Spars)**

**NOTE:** Each number in the setup image identifies the component(s) described in the corresponding step in the following setup instructions.

**NOTE:** *The Knee Flexion System® must be sterilized before use in surgery (see Section 10.2).*

1. Ensure all four (4) Casters are in the locked position.
2. Attach both the left and right Hana® Radiolucent Leg Spars to the table and lock in place.
3. Place the Pelvic Pad on the table. If extra support is desired, slide the Lateral Board Assembly (without Lateral Perineal Post) on the table instead.
4. Slide the Patient Safety Strap in place.
5. Adjust the table to the appropriate height for patient transfer from the stretcher.
6. Put the appropriate size Traction Boot (small, large, or optional extra-large) on the patient's non-operative foot while the patient is on the stretcher.
7. Transfer the patient to the table in the supine position and secure the patient with the Patient Safety Strap.
8. Insert the padded Perineal Post into the table. Move the patient to establish firm contact with the Perineal Post and adjust the Patient Safety Strap as appropriate.
9. Attach the Traction Boot on the non-operative leg to the Traction Mount on the non-operative Leg Spar.
10. Install a Hana® Arm Board with pad to both left and right sides of the table and position the patient's arms out to the side. Secure the patient's arms.
11. Drape the operative side Hana® Radiolucent Leg Spar and attach the sterilized Knee Flexion System® to the operative side Leg Spar.
12. Place the operative foot on the Foot Plate of the Knee Flexion System® and secure according to surgeon protocol.



**Figure 81: Patient Positioned for Total Knee Arthroplasty (with Left and Right Leg Spars)**

Components for Total Knee Arthroplasty, with Left and Right Leg Spars		
<p>Hana® Radiolucent Leg Spar, Left and Right</p> 	<p>Pelvic Pad</p> 	<p>Lateral Board</p> 
<p>Patient Safety Strap</p> 	<p>Traction Boot (Left or Right), Large or Small</p> 	<p>Perineal Post</p> 
<p>Hana® Arm Board with Pad (2)</p> 	<p>Hana® Knee Flexion System®</p> 	

# 9 Optional Accessories

## 9.1 Hana® Table Optional Fracture Kit Components

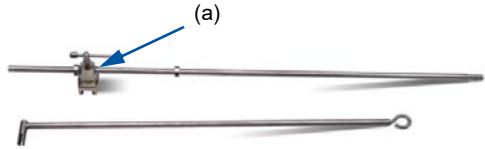
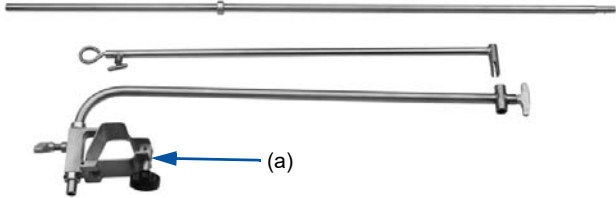

The Hana® Table Fracture Kit, **REF** 6875-2761, includes the following components used for various Orthopedic fracture surgical setups:

**Table 9: Optional Fracture Kit Components**

Component	Description
<p><b>REF</b> 6875-2740 Hana® Patient Transfer Board with Pad</p> 	<p>The Hana® Patient Transfer Board attaches to the Foot-End of the table and provides additional support for the patient's legs during patient transfer. Once the patient is completely secured as described in the appropriate setup instructions, the Hana® Patient Transfer Board is removed.</p> <p>The Hana® Patient Transfer Board comes with a 3-inch (7.6 cm) Tempur-Pedic® Medical Pad.</p> <p>This optional accessory may also be ordered separately.</p>
<p><b>REF</b> 6875-747 Head-End Drape Rod Assembly</p>  <p><b>(a) Modified Clark Socket</b></p>	<p>If Patient Isolation Drapes are to be used, they can be supported on both Head-End and Foot-End Drape Rod Assemblies.</p> <p>The Head-End Drape Rod Assembly includes a Modified Clark Socket to facilitate attachment to the side rail at the Head-End of the table.</p>
<p><b>REF</b> 6875-750 Foot-End Drape Rod Assembly</p>  <p><b>(a) Attachment Clamp Assembly</b></p>	<p>If Patient Isolation Drapes are to be used, they can be supported on both Head-End and Foot-End Drape Rod Assemblies.</p> <p>The Foot-End Drape Rod Assembly includes an Attachment Clamp Assembly to facilitate attachment to the Leg Spar at the Foot-End of the table.</p>





**Table 9: Optional Fracture Kit Components** *(Continued)*





Component	Description
<p><b>REF 6850-180 Mount Bracket for Lateral Perineal Post</b></p> 	<p>This Mount Bracket attaches and secures to the Femur Lift Assembly, and allows mounting of the Lateral Perineal Post (also included in this kit), which can be used in IM Femoral and Tibial Nailing surgical procedures.</p>
<p><b>REF 6850-400 Lateral Perineal Post</b></p> 	<p>The Lateral Perineal Post attaches to the Femur Lift Assembly through the use of the Mount Bracket for Lateral Perineal Post (also included in this kit). It can be used to provide counter-traction in IM Femoral and Tibial Nailing surgical procedures.</p> <p>The Perineal Post is 15 inches long (38.1 cm) and has a 2.75-inch (7 cm) diameter with pad.</p>
<p><b>REF 6850-114 Traction Device Hook</b></p> 	<p>The Traction Device Hook attaches to the Leg Spar Traction Mount and may be used in procedures requiring skeletal traction.</p>
<p><b>REF 5858-1 Patient Isolation Drapes (box of 3)</b></p>	<p>Patient Isolation Drapes are available for use, if desired. These disposable accessories are single-use-only. See Section 7.2 for reorder information.</p>

## 9.2 Hana® Table Recommended Optional Accessories

**Table 10: Recommended Optional Accessories**

Accessory	Description
<p><b>REF 6875-2740 Hana® Patient Transfer Board</b></p> 	<p>The Hana® Patient Transfer Board attaches to the Foot-End of the table and provides additional support for the patient's legs during patient transfer. Once the patient is completely secured as described in the appropriate setup instructions, the Hana® Patient Transfer Board is removed.</p> <p>The Hana® Patient Transfer Board comes with a 3-inch (7.6 cm) Tempur-Pedic® Medical Pad.</p> <p>This optional accessory is also available as part of the Hana® Table Fracture Kit. See Section 9.1 for more information on the kit.</p>
<p><b>REF 3369 Large Diameter Perineal Post</b></p> 	<p>The Large Diameter Perineal Post provides counter-traction, while the urethane foam pad helps relieve pressure on the perineal area. It may be used in place of the Adult Perineal Post that comes standard with the table, if desired. The Perineal Post is 9 inches long (22.8 cm) and has a 6-inch (15.2 cm) diameter with pad.</p> <p>Disposable 6-inch perineal post covers are available (see Section 7.2).</p>
<p><b>REF 6850-420 3-inch Extended Perineal Post</b></p> 	<p>The 3-inch Extended Perineal Post provides counter-traction, while the urethane foam pad helps relieve pressure on the perineal area. It may be used in place of the Adult Perineal Post that comes standard with the table, if desired. The Extended Perineal Post is 14 inches long (35.5 cm) and has a 3-inch (7.6 cm) diameter with pad.</p>





**Table 10: Recommended Optional Accessories** (Continued)

Accessory	Description
<p><b>REF 3368 3-inch Shortened Perineal Post</b></p> 	<p>The 3-inch Shortened Perineal Post provides counter-traction while the urethane foam pad helps relieve pressure on the perineal area. It may be used in place of the Adult Perineal Post that comes standard with the table, if desired. The Shortened Perineal Post is 6 inches long (15.2 cm) and has a 2.75-inch (7 cm) diameter with pad.</p>
<p><b>REF 5857 Cross Arm Support with Pad</b></p> 	<p>The Cross Arm Support may be mounted onto the Hana® Table using a Clark Socket to support the patient's arm over his or her chest. This accessory comes with a one-inch (2.5 cm) Tempur-Pedic® Medical Pad.</p>
<p><b>REF 5393 Clark Socket</b></p> 	<p>The Clark Socket attaches to the side rail of the Hana® Table to facilitate attachment of additional accessories, including the Cross Arm Support.</p>
<p><b>REF 6300-93 90 Degree Pin and Wire Holder, Ovation</b></p> 	<p>The 90 Degree Pin and Wire Holder attaches to the Leg Spar Traction Mount with the ProFx® Traction Boot Adapter Assembly and may be used in procedures requiring skeletal traction.</p>



**Table 10: Recommended Optional Accessories** (Continued)

Accessory	Description
<p><b>REF 5862 Kirschner Bow Holder</b></p> 	<p>The Kirschner Bow Holder attaches to the Leg Spar Traction Mount with the ProFx® Traction Boot Adapter Assembly and may be used in procedures requiring skeletal traction.</p>
<p><b>REF 6850-27 ProFx® Traction Boot Adapter Assembly</b></p> 	<p>The ProFx® Traction Boot Adapter Assembly attaches to the Leg Spar Traction Mount to facilitate attachment of the Kirschner Bow Holder and 90 Degree Pin and Wire Holder for procedures requiring skeletal traction.</p>
<p><b>REF 5855-411 Tibia Traction Upright</b></p> 	<p>The Tibia Traction Upright attaches to the Hana® Radiolucent Leg Spar near the Foot-End and supports the Traction Unit. It can be used during IM Femoral Nailing procedures.</p>
<p><b>REF 5855-345 Traction Unit</b></p> 	<p>The Traction Unit attaches to the Tibia Traction Upright and provides fine traction adjustment. The Traction Foot Plate Assembly can be attached directly to the Traction Unit. The Traction Boot can be attached to the Traction Unit with the Tibial Traction Boot Adapter.</p>
<p><b>REF 5855-440 Traction Foot Plate Assembly</b></p> 	<p>The Traction Foot Plate Assembly can be used to secure the patient's foot to the Traction Unit.</p>
<p><b>REF 6850-487 Traction Boot, Extra-Large Pair</b></p> 	<p>The Traction Boots secure the patient's feet to the Leg Spars for procedures requiring skin traction. The optional Extra-Large size is available for use on patients when the standard sizes do not fit.</p> <p>The standard black boot liners can be replaced. In addition, disposable boot liners are available (see Section 7.2).</p>
<p><b>REF FE00388 Boot Liners, Extra-Large Pair</b></p>	

**Table 10: Recommended Optional Accessories** *(Continued)*

Accessory	Description
<p><b>REF 6850-25 Tibial Traction Boot Adapter</b></p> 	<p>The Tibial Traction Boot Adapter attaches to the Traction Unit to facilitate attachment of the Traction Boot.</p>
<p><b>REF 6850-170 Lower Leg Support</b></p> 	<p>The Lower Leg Support attaches to the Hana® Radiolucent Leg Spar with an Accessory Clamp. It can be used to provide additional support for the patient's operative leg.</p> <p>This accessory comes with a one-inch (2.5 cm) Tempur-Pedic® Medical Pad.</p>
<p><b>REF 5855-61 Accessory Clamp</b></p> 	<p>The Accessory Clamp attaches to the Hana® Radiolucent Leg Spar, allowing various accessories to be mounted.</p>
<p><b>REF 6875-500 Hana® Equipment Cart</b></p> 	<p>The Hana® Equipment Cart may be used to store Hana® Table components and accessories when not in use.</p>

**Table 10: Recommended Optional Accessories (Continued)**

Accessory	Description
<p><b>REF 6950 Tempur-Pedic® Medical Positioning Pad Set, 6-piece</b></p>  <p>(a) <b>REF 6950-01 Tempur-Pedic® Medical Knee Block A</b>                  (b) <b>REF 6950-02 Tempur-Pedic® Medical Knee Block B</b>                  (c) <b>REF 6950-03 Tempur-Pedic® Medical Basic Roll</b>                  (d) <b>REF 6950-04 Tempur-Pedic® Medical Spinal Wedge</b>                  (e) <b>REF 6950-05 Tempur-Pedic® Medical Cradle Block</b>                  (f) <b>REF 6950-06 Tempur-Pedic® Medical Rectangular Pad</b></p>	<p>This 6-piece pad set includes two knee blocks, a basic roll, a spinal wedge, a cradle block and a rectangular pad to assist with patient positioning.</p>
<p><b>REF 10706 Orange Aid® Universal Traction Boot Liner</b></p> 	<p>This reusable Traction Boot liner may be used with all sizes of Traction Boots available with the Hana® Table. The liner helps cushion the patient's foot when inside the Traction Boot.</p>
<p><b>REF 10704 Orange Aid® Universal Perineal Post Pad</b></p> 	<p>This reusable 11" x 9" x 3/8" pad helps prevent potential pressure complications when used with standard and optional perineal posts available for the Hana® Table. The pad is not compatible with the optional Large Diameter Perineal Post.</p>

### 9.3 Hana® Patient Transfer Board Assembly

The Hana® Patient Transfer Board is designed to work with the Jack Mount Assembly to provide a large surface to aid in transferring a patient to and from the Hana® Table.



**CAUTION: The Hana® Patient Transfer Board is not intended to work as a surgical platform. It should be removed prior to surgery to avoid interference with operation of the Leg Spars and other equipment used during the surgery.**

The Hana® Patient Transfer Board may be installed and removed under the following conditions:

- With the Leg Spars either on the table or off the table
- With one Leg Spar and Well Leg Support Assembly installed
- With or without the Femur Lift Assembly installed
- With the Lateral Board and Lateral Perineal Post installed
- With or without a patient on the table in any of the above setup situations

**NOTE:** *With a patient on the table using two Leg Spars, the Spars may need to be abducted 10° to 20° each so that the Hana® Patient Transfer Board can be removed from between the Spars and the patient's legs.*



**Figure 82: Patient on the Table and Hana® Patient Transfer Board Ready for Removal**

### 9.3.1 Installing the Hana® Patient Transfer Board on the Table

To install the optional Hana® Patient Transfer Board:

1. Make sure the Jack Mount Assembly is securely attached to the table (see Section 6.9).
2. Remove the 3-inch Tempur-Pedic® pad from the Hana® Patient Transfer Board.
3. Hold the Hana® Patient Transfer Board by the hard plastic top and guide the long arms into the guide fins on the Jack Mount Assembly.

The Hana® Patient Transfer Board will stop when the small bolt on the bottom of the long arms contacts the front of the guide fin. When fully installed, there should be a slight gap between the Hana® Patient Transfer Board and the table top.



**Figure 83: Hana® Patient Transfer Board Ready to Install**

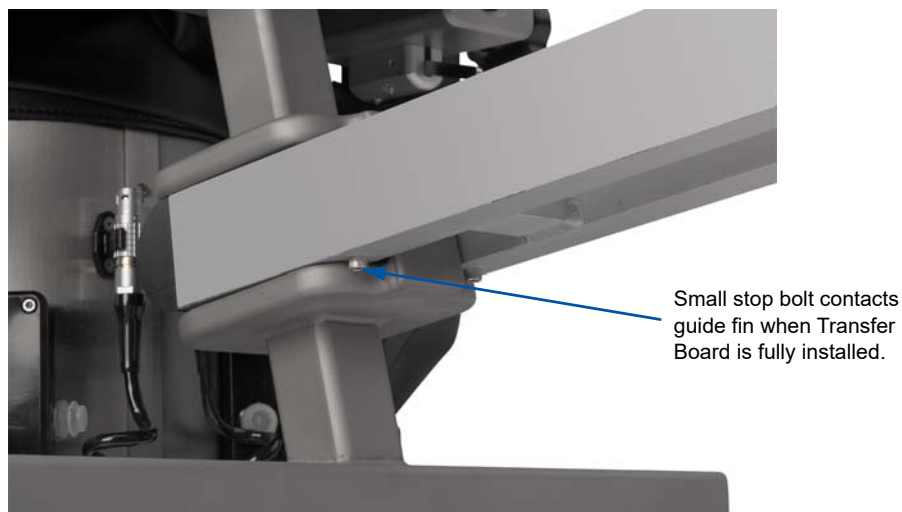

**Figure 84: Stop Bolt on Hana® Patient Transfer Board in Contact with Guide Fin**



**NOTE:** A second person may assist with proximal positioning of the Hana® Patient Transfer Board, as needed.

4. Replace the 3-inch Tempur-Pedic® pad onto the Hana® Patient Transfer Board.

**NOTE:** The pads may be slightly out of alignment when the Hana® Patient Transfer Board is installed.



**Figure 85: Hana® Patient Transfer Board Installed**

### 9.3.2 Removing the Hana® Patient Transfer Board from the Table

To remove the Hana® Patient Transfer Board:

1. Remove the 3-inch Tempur-Pedic® pad from the Hana® Patient Transfer Board.
2. Grasp the Hana® Patient Transfer Board by the hard plastic top and pull distally and slightly upward.



**Figure 86: Removing the Hana® Patient Transfer Board**

## 9.4 Optional Lateral Perineal Post

The Lateral Perineal Post that is included in the Hana® Table Fracture Kit can be used during IM Tibial Nailing or Retrograde IM Femoral Nailing procedures. Since it is attached to the Femur Lift Assembly, it can be raised or lowered as needed during setup.

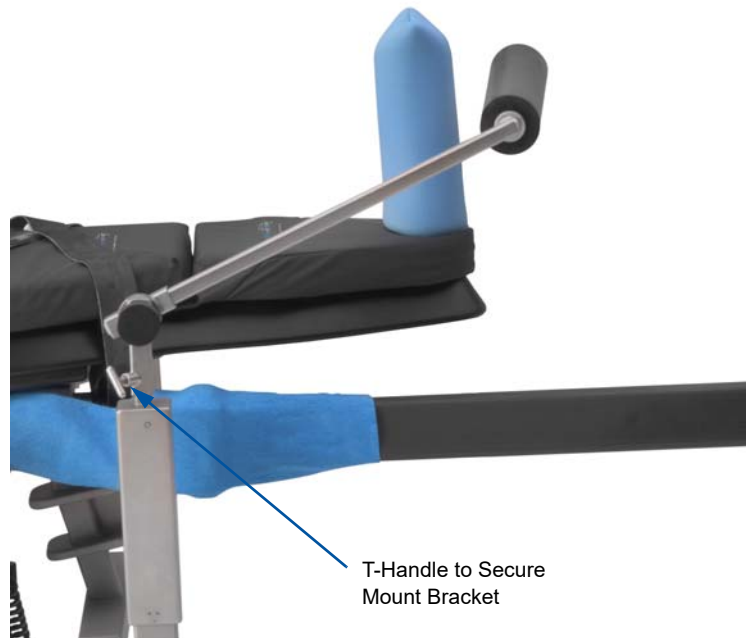

**Figure 87: Lateral Perineal Post Installed on Femur Lift Assembly**

To install the Lateral Perineal Post:

1. Ensure the Femur Lift Assembly is properly set up and powered, as described in Section 6.10.
2. Attach the Mount Bracket for the Lateral Perineal Post to the top of the Femur Lift Assembly. Rotate the lower T-Handle on the Mount Bracket to secure it to the Femur Lift Assembly (Figure 87).
3. Attach the Lateral Perineal Post to the Mount Bracket. Rotate the upper T-Handle on the Mount Bracket to secure the Lateral Perineal Post (Figure 88).
4. To adjust the angle of the Lateral Perineal Post:



**Figure 88: Adjusting the Lateral Perineal Post**

- a. Rotate the Lock Knob on the Mount Bracket counterclockwise to loosen the two halves of the Mount Bracket (Figure 89).



**Figure 89: Lock Knob on Mount Bracket**

- b. Adjust the angle of the Lateral Perineal Post, as needed.
- c. Rotate the Lock Knob on the Mount Bracket clockwise to secure in the new position.



**WARNING:** It is important that the Lateral Perineal Post be placed against the distal femur, two to three inches proximal to the popliteal fossa. Placement of the post into the fossa may result in a potential neurological or circulatory injury.

## 9.5 Cross Arm Support

To install the Cross Arm Support:

1. Mount a Clark Socket on the side rail of the Hana® Table.
2. Place the Cross Arm Support upright in the Clark Socket. Turn the Clark Socket handle clockwise to secure the Cross Arm Support upright (Figure 90).

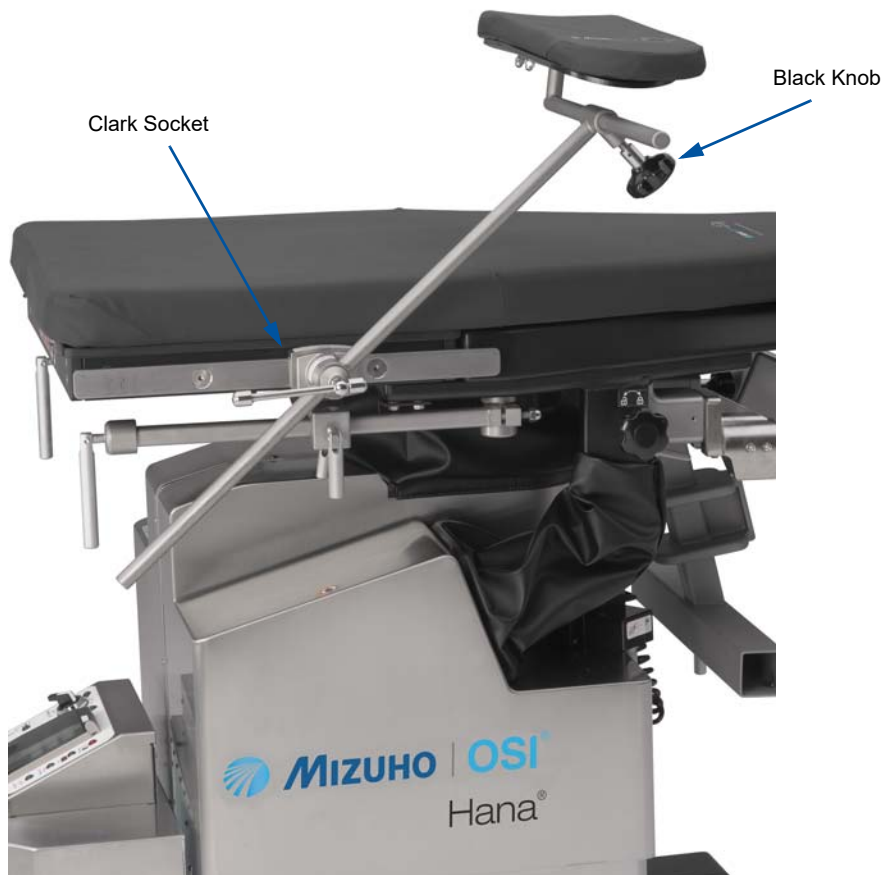

**Figure 90: Cross Arm Support Mounted to Table with a Clark Socket**

3. Insert the Cross Arm Support into the Cross Arm Support upright, and secure by turning the black knob clockwise,
4. Position the Cross Arm Support over, but not in contact with, the patient's chest.
5. Pad and secure the patient's arm to the Cross Arm Support.

## 9.6 Lower Leg Support

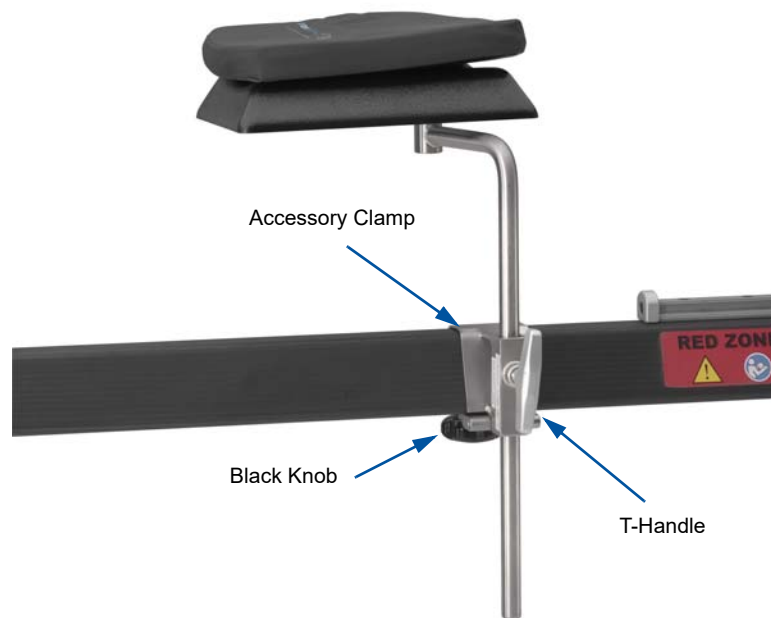

**Figure 91: Lower Leg Support Assembly Secured to Leg Spar**

To attach the Lower Leg Support Assembly:

1. Slide the Accessory Clamp on the appropriate Hana® Radiolucent Leg Spar with the black knob facing down and the receiver on the non-operative side of the table.
2. Rotate the black knob clockwise to secure the clamp in place.
3. Insert the Lower Leg Support Assembly in the Accessory Clamp.
4. Rotate the T-Handle on the clamp clockwise to secure the Leg Support Assembly in place.

## 9.7 Tibial Traction Assembly

The Tibial Traction Assembly can be used to support the operative leg during procedures requiring skeletal traction. This configuration of optional accessories can provide proximal and distal traction at the same time, if desired.



Foot Plate attached to Tibial Traction Assembly

Traction Boot attached to Tibial Traction Assembly

**Figure 92: Tibial Traction Assembly Attached to Leg Spar**

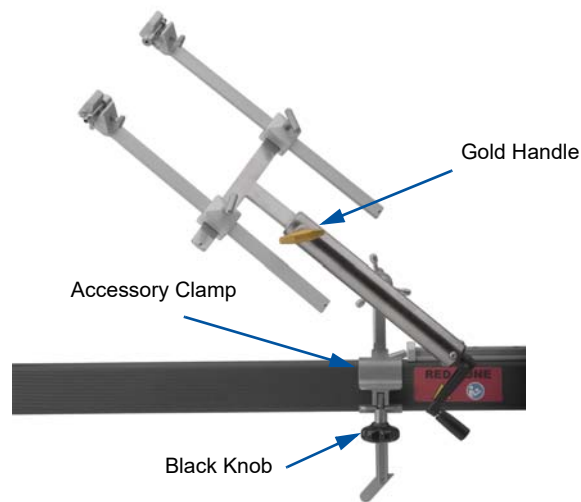

**Figure 93: Tibial Traction Assembly Attached to Leg Spar and Using Secondary Skeletal Traction (90 Degree Pin and Wire Holder)**

To attach the Tibial Traction Assembly:

1. Slide the Accessory Clamp on the operative Hana® Radiolucent Leg Spar with the black knob facing down and the receiver facing the non-operative side of the table.
2. Rotate the black knob clockwise to secure the clamp in place.
3. Insert the Tibial Traction Upright in the Accessory Clamp from the bottom with the Traction Unit Receiver facing the operative side of the table. Rotate the T-Handle on the Accessory Clamp clockwise to secure the Tibial Traction Upright in place.
4. Attach the Traction Unit to the Tibia Traction Upright.
5. If using the Traction Boot:
  - a. Attach the Tibial Traction Boot Adapter to the Traction Unit.
  - b. Rotate the Gold Handle on the Traction Unit clockwise to secure the adapter.
  - c. Once the patient has been transferred and secured to the table, attach the Traction Boot to the Tibial Traction Boot Adapter.
6. If using the Traction Foot Plate Assembly:
  - a. Attach the Traction Foot Plate Assembly to the Traction Unit
  - b. Rotate the Gold Handle on the Traction Unit clockwise to secure the Foot Plate.
7. If pulling secondary skeletal traction to the distal tibia:
  - a. Attach the 90 Degree Pin and Wire Holder to the Traction Unit.
  - b. Rotate the Gold Handle on the Traction Unit clockwise to secure the Holder.

**NOTE:** *The Kirschner Bow Holder may also be used.*

## 9.8 Drape Rod Assemblies

If Patient Isolation Drapes are used, attach the Drape Rod Assemblies at the Head-End and Foot-End of the Hana® Table (Figure 94).

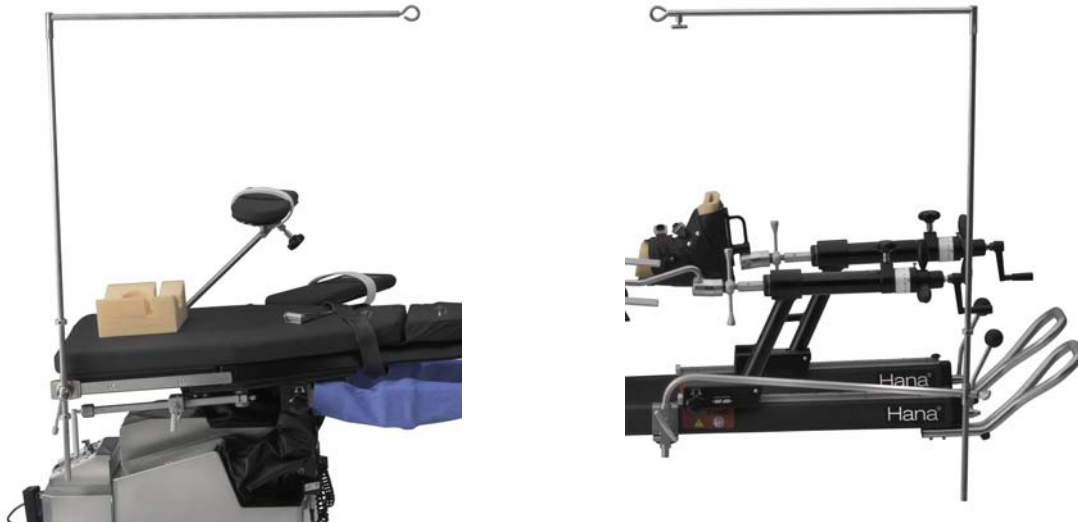

**Figure 94: Head-End and Foot-End Drape Rod Assemblies Attached to Table**

### 9.8.1 Head-End Drape Rod Assembly

To attach the Head-End Drape Rod Assembly:

1. Slide the Modified Clark Socket on the table side rail at the Head-End of the Hana® Table (Figure 95).



**Figure 95: Attaching Modified Clark Socket to Side Rail**



2. Insert the Drape Hanger Upright into the Modified Clark Socket and rotate the T-Handle on the Clark Socket clockwise to secure the Upright in place (Figure 96).



**Figure 96: Securing Drape Hanger Upright into Modified Clark Socket**

3. Attach the Head-End Drape Hanger Top Rail to the top of the Drape Hanger Upright and position over the table as shown in Figure 94.

### 9.8.2 Foot-End Drape Rod Assembly

To attach the Foot-End Drape Rod Assembly:

1. Mount the Attachment Clamp Assembly to the operative side Leg Spar with the black knob facing down and the receiver on the operative side of the table (Figure 97).



**Figure 97: Attaching Attachment Clamp Assembly to Leg Spar**

2. Rotate the black knob clockwise to secure the clamp in place.
3. Insert the Drape Hanger Upright into the Attachment Clamp Assembly and rotate the T-Handle on the Clamp to secure the Upright in place.



**Figure 98: Drape Hanger Upright Secured to Attachment Clamp Assembly**

4. Attach the Foot-End Drape Hanger Top Rail to the top of the Drape Hanger Upright and position over the table as shown in Figure 94.

## 9.9 Equipment Cart

The optional Hana® Equipment Cart may be used to store the Hana® Table components and accessories when not in use. The Equipment Cart Cover provided with the Cart serves as a dust cover and should be used while the products are in storage.



**Figure 99: Equipment Cart, Front and Back (Empty)**

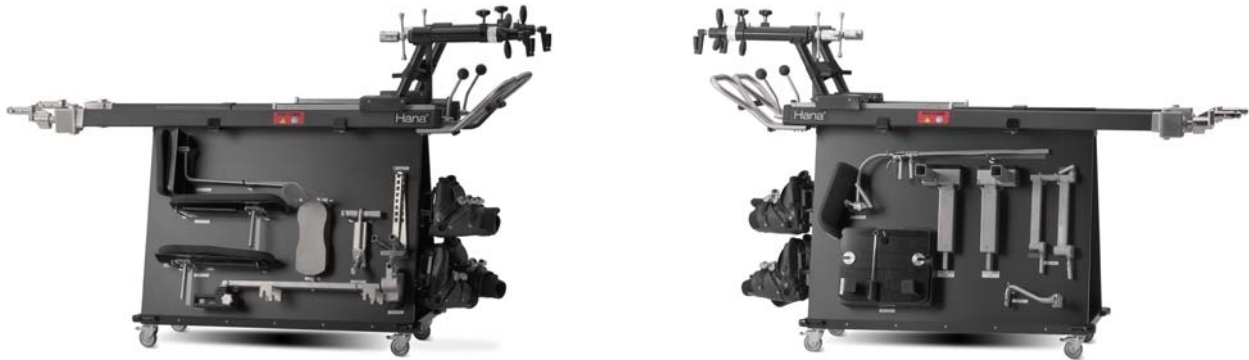

**Figure 100: Equipment Cart, Front and Back (Loaded)**

# 10 Cleaning, Sterilization, and Maintenance

---

## 10.1 Cleaning and Disinfecting

### 10.1.1 Table Exterior

The exterior surface should be regularly wiped clean with a mild detergent solution and wiped dry with a soft lint-free cloth. This includes the table pad and tabletop.

Care should be taken to avoid exposing the table to excessive moisture. Flooding, fogging, or steam cleaning is not recommended.



**CAUTION:** Never pour any liquid directly onto the table. Never subject the Hana® Table to an equipment washing machine.

Blood or other fluids, etc., if allowed to remain on the table for a long period of time, will require special cleaning to remove. A 5% acetic acid solution or white vinegar and water solution is especially good for this purpose.

**NOTE:** Use of iodophors will cause staining.

To remove staining or discoloration of plated or stainless steel surfaces, clean with a good commercial cleaning compound labeled for stainless steel and then buff the surface by hand.

To disinfect exterior surfaces, use a quaternary ammonium compound according to manufacturer's directions for use. Wipe dry with a soft lint-free cloth.

**NOTE:** Failure to thoroughly dry the surface after cleaning and disinfecting may result in rust.

**NOTE:** When cleaning the Leg Spars, ensure that the track is completely dry before moving the Traction Assembly.

### 10.1.2 Mizuho OSI Tempur-Pedic® Medical Pads

**NOTE:** The Mizuho OSI Tempur-Pedic® Medical Pads should always be stored in a flat position. The pads can become stiff in cold temperatures and can crack and break if in a rolled position. It is important that you allow the pads to warm to room temperature before attempting to use or handle.

When handling a Tempur-Pedic® Medical Pad, always grasp the entire thickness of the pad.



**CAUTION:** DO NOT lift, slide, or carry Mizuho OSI Tempur-Pedic® Medical Pads by grabbing the fabric cover. The cover may tear or rip.

The pads are intended to be cleaned in place. They do not need to be rotated or removed.

Clean with standard hospital disinfectants labeled for use on table pads. Always dilute and rinse per manufacturer's label instructions. Wipe dry with a lint-free cloth. DO NOT soak or autoclave the pads. Clean the pad on the tabletop, wipe dry with a lint free cloth, and then reposition the pad to lie flat on the tabletop.

**NOTE:** *The use of bleach or highly concentrated chemicals may discolor the cover and will void the warranty on the pad.*

When cleaning the bottom of the pad on the tabletop, simply lift one end of the pad, and fold it over onto the other end. Clean the pad on the tabletop, wipe dry with a lint-free cloth, and then reposition the pad to lie flat on the tabletop.

### 10.1.3 Femoral Hook Support and Femoral Hook

Prior to each patient use, inspect, clean, and sterilize the Femoral Hook(s) and Femoral Hook Support according to the hospital's protocol for reprocessing surgical instruments.

Do not use steel wool, wire brushes, pipe cleaners or abrasive detergents. Use of anything other than high quality brushes designed for surgical instrument cleaning may result in damage.

Disassembly of the Femoral Hook Support before cleaning is not necessary unless severely soiled or dictated by hospital policy.

Do not use high acid (pH 4 or lower) or high alkaline (pH 10 or higher) disinfectant products, such as bleach and bi-chloride of mercury.

### 10.1.4 Hana® Knee Flexion System®

Prior to each patient use, inspect, clean, and sterilize the Knee Flexion System® according to the hospital's protocol for reprocessing surgical instruments.

Do not use steel wool, wire brushes, pipe cleaners, or abrasive detergents. Use of anything other than high quality brushes designed for surgical instrument cleaning may result in damage.

Disassembly of the Knee Flexion System® before cleaning is not necessary unless severely soiled or dictated by hospital policy.

Do not use high acid (pH 4 or lower) or high alkaline (pH 10 or higher) disinfectant products, such as bleach or bi-chloride of mercury.

## 10.2 Sterilization

The Femoral Hook Support, Femoral Hook(s), and Hana® Knee Flexion System® must be sterilized before use. Sterilization of these components is accomplished by steam. To achieve a sterility assurance level of  $10^{-6}$ , Mizuho OSI recommends the sterilization parameters listed below:

**Table 11: Recommended Sterilization Parameters**

Sterilization Method	Temperature	Containment Type	Minimum Exposure Time Range
Gravity Steam	270 °F/132 °C	Wrapped	10 Minutes
Pre-Vacuum Steam	270 °F/132 °C	Wrapped	4 Minutes
Gravity Steam	254 °F/123 °C	Wrapped	30 Minutes

Other sterilization cycles may also be suitable. However, individuals or hospitals not using the recommended methods are advised to validate any alternative methods using current good laboratory practices (cGLP).

**NOTE:** Mizuho OSI does not recommend flash or chemical sterilization of the Femoral Hooks, Femoral Hook Support, or Hana® Knee Flexion System®.

### 10.3 Maintenance



**CAUTION:** Whenever servicing the table, personnel are required to wear personal protective equipment (work jackets, leather gloves, and safety glasses) whenever moving or removing parts and components, or replacing sheet metal covers.

Cleaning the table surfaces and table pad after each use will ensure many years of trouble-free service.

All components are lubricated for life at the factory and no other lubrication for the table is required.

Preventative Maintenance:

Contact Mizuho OSI Service for a complete preventative maintenance checklist.

For detailed repair information or to order replacement parts, call, or contact via the web Mizuho OSI Service:

1-800-777-4674, Option 2 (calls within the USA)

Or

+1-510-429-1500, Option 2 (calls outside the USA)

+1-510-429-8500 (Fax, Domestic and International)

[service@mizuhosi.com](mailto:service@mizuhosi.com)

[www.mizuhosi.com](http://www.mizuhosi.com)

Mizuho OSI Service is available from 5 am to 5 pm Pacific Time, Monday through Friday.

Please leave a message at the extension after normal business hours.

# 11 Electrical System

## 11.1 Description

The electrical system provides control of all table functions and includes the following:

- Power Cord
- On/Off Circuit Breaker Power Switch
- Component Circuit Breakers
- Linear Actuators
- Battery System
- Hana® Hand Pendant
- Motion Control Module
- Electric Motors

Electric motor driven lead screw-type actuators	Manipulate the Height, Lateral Roll and Trendelenburg functions, which are controlled by the Hana® Hand Pendant.
Input power requirement for the Hana® Table	As indicated on the manufacturer's label: 6875J: 100V, 50/60Hz, 4A 6875: 120V, 60Hz, 4A 6875I: 220-230V, 50/60Hz, 2.5A

The input power requirement is 100V, 50/60Hz, 4A; 120V, 60Hz, 4A; or 220-230V, 50/60Hz, 2.5A; and 10%/6 minute duty cycle, as indicated on the serial number label. Refer to the Hana® Table Electrical Interconnect Diagram in Section 13.2 for details on the electrical system.

The primary components of the electrical control system are contained in the Motion Control Box at the Head-End of the table.

## 11.2 Power Cord

The table is equipped with a detachable Power Cord. The Power Cord is connected to the table at the Power Cord Receptacle located below the On/Off Power Switch on the Motion Control Box.

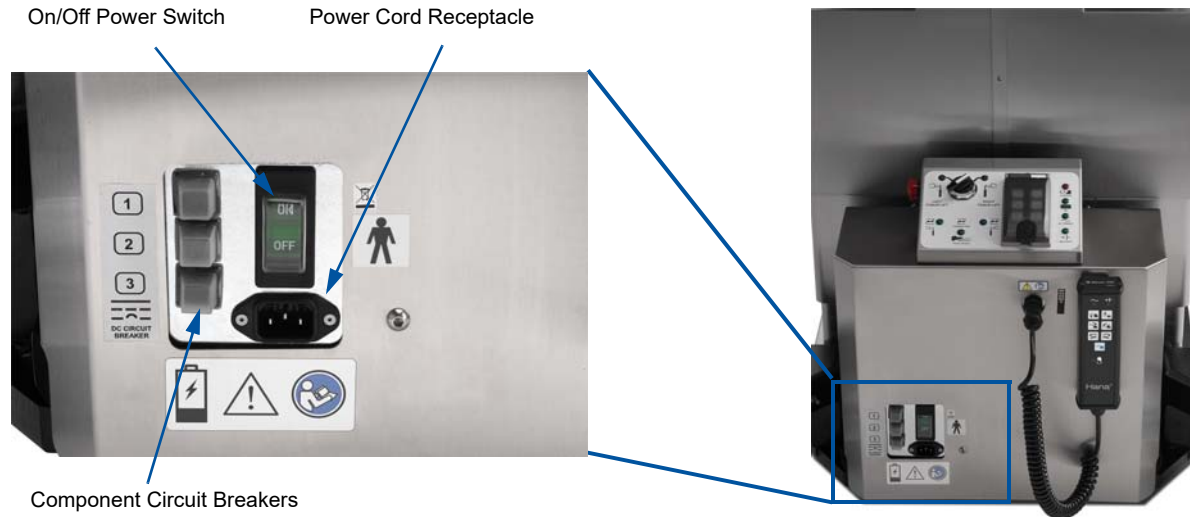

**Figure 101: Head-End Motion Control Box**



**WARNING: Use only Mizuho OSI supplied Power Cords.**

**NOTE:** *Country-specific Power Cords are available. Please contact your Mizuho OSI representative for proper selection.*

## 11.3 On/Off Circuit Breaker Power Switch

An illuminated On/Off Power Switch and Circuit Breaker is located on the Head-End of the table. When illuminated, it indicates that the table is plugged into a live electrical AC outlet and the power is on.

**NOTE:** *When the Power Switch is toggled On and the table is operating under battery power, this switch will not illuminate.*

This switch also serves as a Circuit Breaker. In the event of an overload condition, this switch will trip off. To reset, push to the Off position and then to the On position.

**NOTE:** *Determine the source of the overload prior to resetting this switch.*



## 11.4 Component Circuit Breakers

The electrical system includes individual component 24-V DC Circuit Breakers located at the Head-End of the table. If a short circuit occurs in the low voltage circuit, the breaker will trip as indicated by a button protruding from the access hole. To reset, press the button in and release.



**CAUTION:** Determine the source of the overload prior to resetting this switch. If unable to determine and fix the source of the failure, contact Mizuho OSI Service for additional support.

## 11.5 Linear Actuators

There are four linear actuators in the Base:

- Two of the actuators are 24V motion system actuators, located in the left and right Tilt/Trendelenburg motor assembly.
- The other two actuators are 24V motion system actuators, located in the height up/down motor assembly.

## 11.6 Battery System

The Hana® Table is equipped with a battery system that provides power to all functions, and consists of two batteries (REF NV0801). Due to the relatively low power consumption of the Hana® Table, it can be used on battery power for up to 12 hours at 10% duty cycle.



**CAUTION:** Whenever servicing the table, personnel are required to wear personal protective equipment (work jackets, leather gloves and safety glasses) whenever moving or removing parts and/or components, or replacing sheet metal covers.



**WARNING:** This symbol indicates an external ground stud that is required for use when the AC power cable is not connected to a protective earth ground hospital-grade AC outlet in your operating room or facility. To protect the patient, hospital staff, and the table from possible electrical hazards, an external ground wire connection is required between the external ground stud and protective earth ground.

Battery charge status is shown via LEDs on the Power Indicator section of the Control Panel (Figure 4) and the Hana® Hand Pendant (Figure 6).

- If the Battery Status LED on the Hand Pendant or the Battery OK LED on the Control Panel is illuminated green, the battery is charged and ready for use.
- If the Battery Status LED on the Hand Pendant or the Battery Charge LED on the Control Panel is illuminated red, the battery must be recharged.

If a recharge is required, the batteries must be charged for a minimum of 3 hours. Fully discharged batteries will require 18 hours for a complete charge. To charge the batteries, simply plug the Power Cord into an appropriate hospital grade AC outlet and turn the Power Switch on. It is important to plug in the table as soon as possible after the Battery Status or Battery Charge LED is illuminated red.

If the battery fails to hold a charge, it should be replaced. Replace only with an identical type and size battery.

Replace both batteries at the same time.

At a minimum, the batteries should be replaced once every five (5) years.

Whenever the battery cover is opened, check the battery for signs of corrosion. The battery terminals should be clean and free from corrosion, oil, grease, dirt, or other contaminants.

Battery ordering number: **REF** NV0801.

**NOTE:** *Failure to use an approved Mizuho OSI battery voids the warranty and can cause harm to the table.*



**CAUTION:** Battery life can be shortened if the table remains unplugged and turned on for an extended period of time with the red battery charge light illuminated. While in storage, it is recommended that the table be plugged in and the Power Switch turned on so that the batteries remain charged. If this is not possible, the batteries must be charged for at least three hours per week under normal use conditions. This can be accomplished when using the table under AC power since the system batteries are automatically charged while the table is plugged in and turned on.

# 12 Troubleshooting

**NOTE:** *The Power Switch must be turned off before disconnecting or connecting the Hana® Hand Pendant.*

**Table 12: Troubleshooting Procedures**

Problem	Solution
<p>Table is “dead”; no functions are operational</p>	<ol style="list-style-type: none"> <li>1. Verify that the Power Cord is plugged into an appropriate AC receptacle and into the Power Cord receptacle (located at the base of the Motion Control Box).</li> <li>2. Verify that the Power Switch is on and illuminated. If the Power Switch is not illuminated, the table may still operate on internal battery power. (The Hana® Hand Pendant control buttons and light will be illuminated.)</li> <li>3. Verify that the Circuit Breaker (that is part of the Power Switch located at the base of the Motion Control Box) is not tripped (indicating table power overload). To reset the Circuit Breaker, toggle the Power Switch off, and then on.</li> <li>4. Verify the Component Circuit Breakers (located at the base of the Motion Control Box) are not tripped (indicating component power-overload condition). If the three Component Circuit Breakers are tripped, the buttons will be protruding from the Circuit Breaker access holes. To reset the Component Circuit Breakers, press the buttons. Find the source of the overload prior to resetting.</li> <li>5. If the problem persists, call Mizuho OSI Service. 1-800-777-4676, Option 2 (within the USA) +1-510-429-1500, Option 2 (outside the USA)</li> </ol>

**Table 12: Troubleshooting Procedures (Continued)**

Problem	Solution
The tabletop does not move when Height (Up/Down), Lateral Tilt (Right/Left), or Trendelenburg/Reverse Trendelenburg buttons are pressed	<ol style="list-style-type: none"> <li>1. Verify that the Power Cord is plugged into an appropriate AC receptacle and into the Power Cord receptacle (located at the base of the Motion Control Box).</li> <li>2. Verify that the Power Switch is on and illuminated. If the Power Switch is not illuminated, the table may still operate on internal battery power. (The Hana® Hand Pendant control buttons and light will be illuminated.)</li> <li>3. Verify that the Hana® Hand Pendant is properly connected to the Hand Pendant Receptacle. Ensure that the Hand Pendant control buttons illuminate green.</li> <li>4. Press and hold the corresponding Hana® Hand Pendant button (Height Up/Down, Trendelenburg/Reverse Trendelenburg or Left/Right Lateral Tilt). Observe tabletop movement. If the tabletop does not move when any button is pressed, try using the Control Pad buttons on the Motion Control Box. If the tabletop moves, the Hana® Hand Pendant is damaged and needs to be replaced.</li> <li>5. If the table is on battery power, verify that the battery is adequately charged and the green battery light illuminates.</li> <li>6. If the problem persists, call Mizuho OSI Service. 1-800-777-4676, Option 2 (within the USA) +1-510-429-1500, Option 2 (outside the USA)</li> </ol>
The Return to Level function is not operational	<ol style="list-style-type: none"> <li>1. Verify the Power Cord is plugged into an appropriate AC receptacle and into the Power Cord receptacle (located on table-base panel).</li> <li>2. Press and hold the Return to Level button on the Hana® Hand Pendant. Observe tabletop movement.</li> <li>3. Disorient the tabletop by doing the following:                             <ul style="list-style-type: none"> <li>• Raise the height approximately 2 inches.</li> <li>• Tilt the tabletop laterally approximately 5 degrees.</li> <li>• Activate Trendelenburg approximately 5 degrees.</li> </ul> </li> <li>4. Press and hold the Return to Level button on the Hana® Hand Pendant. Verify that the tabletop levels from side to side first, then levels from front to back, and then, after a three-second delay, moves down to its lowest position.</li> <li>5. If the problem persists, call Mizuho OSI Service. 1-800-777-4676, Option 2 (within the USA) +1-510-429-1500, Option 2 (outside the USA)</li> </ol>
Battery status LED illuminates red	<ol style="list-style-type: none"> <li>1. The battery system requires charging. Charge batteries for a minimum of three (3) hours; plug Power Cord into appropriate hospital-grade AC outlet. <b>NOTE:</b> <i>Power Switch must be toggled to On.</i></li> <li>2. If the problem persists, call Mizuho OSI Service. 1-800-777-4676, Option 2 (within the USA) +1-510-429-1500, Option 2 (outside the USA)</li> </ol>

**Table 12: Troubleshooting Procedures** *(Continued)*

Problem	Solution
Leg spar is loose (not securely attached to the table)	<ol style="list-style-type: none"> <li>1. Verify whether the Spar Lock Handle is stripped.</li> <li>2. If the Spar Lock Handle is stripped, it needs to be replaced. Call Mizuho OSI Service.  1-800-777-4676, Option 2 (within the USA) +1-510-429-1500, Option 2 (outside the USA)</li> </ol>
Leg spar is not holding vertical position (drifting downward)	<ol style="list-style-type: none"> <li>1. Verify that the Spar Lock Handle is rotated clockwise to the locked position.</li> <li>2. Verify that the Leg Spar is securely attached (fully seated and locked) to the table.</li> <li>3. With wear, the Spar Lock Handle may require adjustment to allow adequate movement to the lock position to hold the leg spar. Adjust the Spar Ball Joint Lock Handle lock position as needed.</li> <li>4. If the problem persists, call Mizuho OSI Service.  1-800-777-4676, Option 2 (within the USA) +1-510-429-1500, Option 2 (outside the USA)</li> </ol>

# 13 Technical Drawings and Parts List

## 13.1 Replacement / Spare Parts List

Description	Part Number
Swing Bar, Left (Arm Board Support)	<b>REF</b> 6875-700
Swing Bar, Right (Arm Board Support)	<b>REF</b> 6875-701
Hana® Arm Board	<b>REF</b> 6875-292
Arm Board Contoured Pad (Left and Right)	<b>REF</b> 6850-7600
Drop Handle, Small (on Swing Bars and Jack Mount Assembly)	<b>REF</b> 914-424
Drop Handle (on Swing Bars)	<b>REF</b> 914-516
Batteries (2 Required)	<b>REF</b> NV0801
Caster (4 Required)	<b>REF</b> ND0451
Caster Washer (16 Required)	<b>REF</b> AE040081A
Caster Screw (16 Required)	<b>REF</b> AABB075AAC
Caster Rubber Cap (8 Required)	<b>REF</b> NB0375
Gimbal Kit	<b>REF</b> 6875-9250
Top Cover, Left	<b>REF</b> 6875-85
Top Cover, Right	<b>REF</b> 6875-86
Column Cover, Base	<b>REF</b> 6875-79
Column Cover, Mid-Low	<b>REF</b> 6875-80
Column Cover, Mid-High	<b>REF</b> 6875-81
Column Cover Spacer, Teflon (16 Required)	<b>REF</b> 6875-87
Column Cover Spacer, Brass (4 Required)	<b>REF</b> 6875-88
Column Cover Shim (40 Required)	<b>REF</b> 6875-214
Column Cover Rivet (2 per Spacer)	<b>REF</b> AC012037
Femur Lift Assembly, Right	<b>REF</b> 6875-600
Femur Lift Assembly, Left	<b>REF</b> 6875-601

Description	Part Number
Femur Lift Emergency Crank Handle	REF 6875-602
Coiled Hook Motor Cable	REF 6875-5019
Foot Pedal	REF 6875-5003
Foot Pedal Connector, Table Base	REF 6875-5041
Hana® Hand Pendant	REF 6807-4
Motion Control Box, 120V (for 6875)	REF 6875-4007
Motion Control Box, 220-230V (for 6875I)	REF 6875-4008
Motion Control Box, 100V (for 6875J)	REF 6875-4009
On/Off Power Switch (Circuit Breaker, 115V)	REF NV0946
On/Off Power Switch (Circuit Breaker, 220V)	REF NV0613
AC Power Receptacle	REF NV0585
Control Panel Push Button Assembly	REF 6875-4013
Leg Spar Mount Detent Housing (2 Required)	REF 6875-310
Spar Pressure Arm (2 per Spar)	REF 6850-267
Spar Locking Knob (2 Required)	REF 6875-325
Traction Unit Assembly (2 Required)	REF 6875-2370
Foot Rotation Locking Knob (on Traction Unit)	REF 6875-378
Fine Traction Crank Handle (on Traction Unit)	REF 6850-313
Rotation Brake Pad	REF 6875-376
Gross Traction Brake Assembly, Left	REF 6875-9001
Gross Traction Brake Assembly, Right	REF 6875-9002
Gross Traction Bearing Carriage (1 per Spar)	REF NA0210F
Fine Traction Repair Kit	REF 6850-2230
Power Cord, 120V <b>NOTE:</b> <i>Country specific Power Cords are available. Please contact your Mizuho OSI representative for proper selection.</i>	REF NV0956
Table Lift Motor (2 Required)	REF 6875-5034
Hana® Main Table Pad	REF 6875-7120
Pelvic Pad	REF 6875-7129
Hana® Table Cover	REF 6875-20
Tilt/Trendelenburg Motor (2 Required)	REF 6875-5036
Limit Switch (4 Required)	REF 6875-5042

### 13.2 Interconnect Diagram, 100V, 120V, 220-230V Models

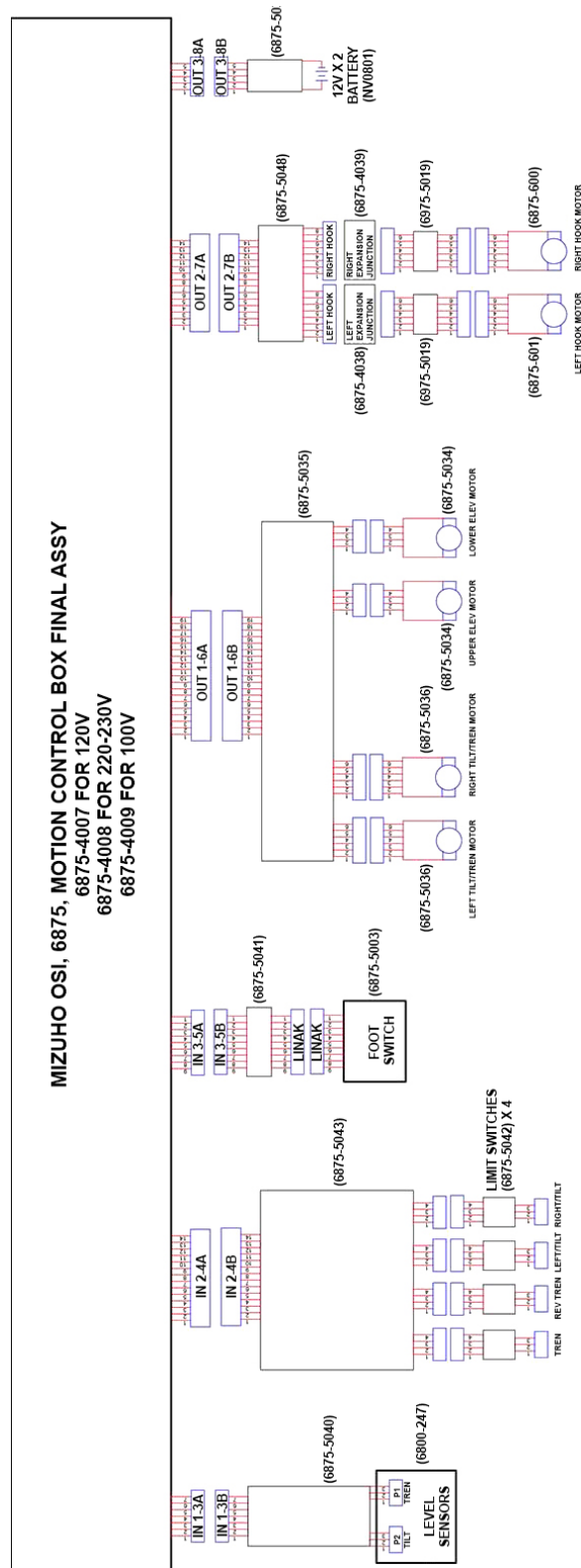



# 14 Technical Support

---

## 14.1 Contact for Parts and Service

For detailed repair information or to order replacement parts, call Mizuho OSI Service at **1-800-777-4674** for calls inside the USA or **+1-510-429-1500** for calls outside the USA. At the prompt, select Option 2.

A Service line is available from 5 AM to 5 PM Pacific Time, Monday through Friday. Please leave a message after business hours.

Please state slowly your name, phone number, your facility name and city, affected equipment model number, and serial number.

An e-mail message may be left anytime at [service@mizuhosi.com](mailto:service@mizuhosi.com) or through the Web Support Form on the web site: [www.mizuhosi.com](http://www.mizuhosi.com).

## 14.2 Order Replacement Parts

If unable to identify a part please call, fax, or e-mail Mizuho OSI Service before placing an order. Once the part number is obtained, follow the instructions below to order the replacement part.

If part is known, please telephone, fax, or e-mail part number and description to Mizuho OSI Service for price and availability.

To place a Replacement Parts (RP) order, please telephone, fax, or e-mail Mizuho OSI Service with the part number, description, price, customer number, and method of shipment with the purchase order. Indicate that the order is for Replacement Parts (RP).

## 14.3 Return Damaged Parts

Identify the part or part number to be returned.

Telephone, fax, or e-mail Mizuho OSI Service with the part number and description of the part for return to obtain a Return Goods Authorization (RGA) number.

Complete the Certificate of Decontamination provided by Mizuho OSI Service.

Return the part with RGA number clearly marked on the outside of the package, and include the Certificate of Decontamination with the shipment.

Complete the Certificate of Decontamination provided by Mizuho OSI Service.

## 14.4 Send a Part for Repair

If unable to identify part, please call, fax, or e-mail Mizuho OSI Service for assistance.

If the part number is known, please call, fax, or e-mail Mizuho OSI Service with the part number and description of the problem to obtain a Repair Authorization (RA) number.

Clean/disinfect parts prior to shipping and complete the Certificate of Decontamination provided by Mizuho OSI Service.

Ship the part with the RA number clearly marked on the outside of the package, and include the Certificate of Decontamination with the shipment.

The part will be evaluated and the customer will be contacted with the cost of repair, if not covered under table warranty.

After customer approval of repair cost, the part will be repaired and returned to the customer.

## 14.5 Warranty

Mizuho OSI products come with a one (1) year warranty against manufacturer defect. All expenses for parts and labor for product service calls are covered free of charge for the warranty period, except those products that are misused, altered, or damaged. All Tempur-Pedic® Medical Pads come with a two (2) year warranty against manufacturer defect. Defective merchandise will be credited or replaced.

## 14.6 European Community Authorized Representative

Emergo Europe  
Prinsessegracht 20  
2514 AP The Hague  
The Netherlands

# 15 Appendix

## 15.1 Electromagnetic Emissions

Guidance and manufacturer's declaration — electromagnetic immunity		
The Hana® Table is intended for use in the electromagnetic environment specified below. The customer or the user of the Hana® Table should assure that it is used in such an environment.		
Emissions test	Compliance	Electromagnetic environment — guidance
RF emissions CISPR 11	Group 1	The Hana® Table uses RF energy only for its internal function. Therefore, its RF emissions are very low and are not likely to cause any interference in nearby electronic equipment.
RF emissions CISPR 11	Class A	The Hana® Table is suitable for use in all establishments other than domestic establishments and those directly connected to the public low-voltage power supply network that supplies buildings used for domestic purposes.
Harmonic emissions IEC 61000-3-2	Class A (230V) Not applicable (100V)	
Voltage fluctuations / flicker emissions IEC 61000-3-3	Complies (230V) Not applicable (100 V)	

## 15.2 Electromagnetic Immunity

Guidance and manufacturer's declaration — electromagnetic immunity			
The Hana® Table is intended for use in the electromagnetic environment specified below. The customer or the user of the Hana® Table should assure that it is used in such an environment.			
Immunity test	IEC 60601 test level	Compliance level	Electromagnetic environment — guidance
Electrostatic discharge (ESD)	±6 kV contact	±6 kV contact	Floors should be wood, concrete or ceramic tile. If floors are covered with synthetic material, the relative humidity should be at least 30%.
IEC 61000-4-2	±8 kV air	±8 kV air	
Electrical fast transient / burst	±2 kV for power supply lines	±2 kV for power supply lines	Mains power quality should be that of a typical commercial or hospital environment.
IEC 61000-4-4	±1 kV for input / output lines	±1 kV for input / output lines	
Surge	± 1 kV line(s) to line(s)	± 1 kV line(s) to line(s)	Mains power quality should be that of a typical commercial or hospital environment.
IEC 61000-4-5	± 2 kV line(s) to earth	± 2 kV line(s) to earth	
Voltage dips, short interruptions and voltage variations on power supply input lines	<5% $U_T$ (>95% dip in $U_T$ ) for 0.5 cycle 40% $U_T$ (60% dip in $U_T$ ) for 5 cycles 70% $U_T$ (30% dip in $U_T$ ) for 25 cycles <5% $U_T$ (>95% dip in $U_T$ ) for 5 s	<5% $U_T$ (>95% dip in $U_T$ ) for 0.5 cycle 40% $U_T$ (60% dip in $U_T$ ) for 5 cycles 70% $U_T$ (30% dip in $U_T$ ) for 25 cycles <5% $U_T$ (>95% dip in $U_T$ ) for 5 s	Mains power quality should be that of a typical commercial or hospital environment. If the user of the Hana® Table requires continued operation during power mains interruptions, it is recommended that the Hana® Table be powered from an uninterruptible power supply or a battery.
Power frequency (50/60 Hz) magnetic field	3 A/m	3 A/m	Power frequency magnetic fields should be at levels characteristic of a typical location in a typical commercial or hospital environment.
IEC 61000-4-8			
Note: $U_T$ is the a.c. mains voltage prior to application of the test level.			

Guidance and manufacturer's declaration — electromagnetic immunity			
The Hana® Table is intended for use in the electromagnetic environment specified below. The customer or the user of the Hana® Table should assure that it is used in such an environment.			
Immunity test	IEC 60601 test level	Compliance level	Electromagnetic environment — guidance
			Portable and mobile RF communications equipment should be used no closer to any part of the Hana® Table including cables, than the recommended separation distance calculated from the equation applicable to the frequency of the transmitter.
Conducted RF IEC 61000-4-6	3 V <sub>rms</sub> 150 kHz to 80 MHz	3 V	<b>Recommended separation distance</b> $d = 1.2\sqrt{P}$
Radiated RF IEC 61000-4-3	3 V/m 80 MHz to 2.5 GHz	3 V/m	$d = 1.2\sqrt{P}$ 80MHz to 800MHz  $d = 2.3\sqrt{P}$ 800MHz to 2.5GHz  Where <i>P</i> is the maximum output power rating of the transmitter in watts (W) according to the transmitter manufacturer and <i>d</i> is the recommended separation distance in meters (m).  Field strengths from fixed RF transmitters, as determined by an electromagnetic site survey, <sup>a</sup> should be less than the compliance level in each frequency range. <sup>b</sup>  Interference may occur in the vicinity of equipment marked with the following symbol:  
<p>Note 1: At 80 MHz and 800 MHz, the higher frequency range applies.</p> <p>Note 2: These guidelines may not apply in all situations. Electromagnetic propagation is affected by absorption and reflection from structures, objects and people.</p> <p><sup>a</sup> Field strengths from fixed transmitters, such as base stations for radio (cellular/cordless) telephones and land mobile radios, amateur radio, AM and FM radio broadcast and TV broadcast cannot be predicted theoretically with accuracy. To assess the electromagnetic environment due to fixed RF transmitters, an electromagnetic site survey should be considered. If the measured field strength in the location in which the Hana® Table is used exceeds the applicable RF compliance level above, the Hana® Table should be observed to verify normal operation. If abnormal performance is observed, additional measures may be necessary, such as re-orienting or relocating the Hana® Table.</p> <p><sup>b</sup> Over the frequency range 150kHz to 80MHz, field strengths should be less than 3 V/m.</p>			

### 15.3 Recommended Separation Distances

Recommended separation distances between portable and mobile RF communications equipment and the Hana® Orthopedic Surgery Table			
The Hana® Table is intended for use in an electromagnetic environment in which radiated RF disturbances are controlled. The customer or the user of the Hana® Table can help prevent electromagnetic interference by maintaining a minimum distance between portable and mobile RF communications equipment (transmitters) and the Hana® Table as recommended below, according to the maximum output power of the communications equipment.			
Rated maximum output power of transmitter <b>W</b>	Separation distance according to frequency transmitter <b>m</b>		
	150 kHz to 80 MHz $d = 1.2\sqrt{P}$	80 MHz to 800 MHz $d = 1.2\sqrt{P}$	800 MHz to 2.5 GHz $d = 2.3\sqrt{P}$
0.01	0.12	0.12	0.23
0.1	0.37	0.37	0.74
1	1.2	1.2	2.3
10	3.7	3.7	7.4
100	12	12	23
For transmitters rated at a maximum output power not listed above, the recommended separation distance $d$ in meters (m) can be estimated using the equation applicable to the frequency of the transmitter, where $P$ is the maximum output power rating of the transmitter in watts (W) according to the transmitter manufacturer.			
Note 1: At 80 MHz and 800 MHz, the separation distance for the higher frequency range applies.			
Note 2: These guidelines may not apply in all situations. Electromagnetic propagation is affected by absorption and reflection from structures, objects and people.			